

eduard



INSTRUCTION SHEET

USS Arizona
1/350 Limited Edition

LN01-NAV1

USS ARIZONA

BB-39

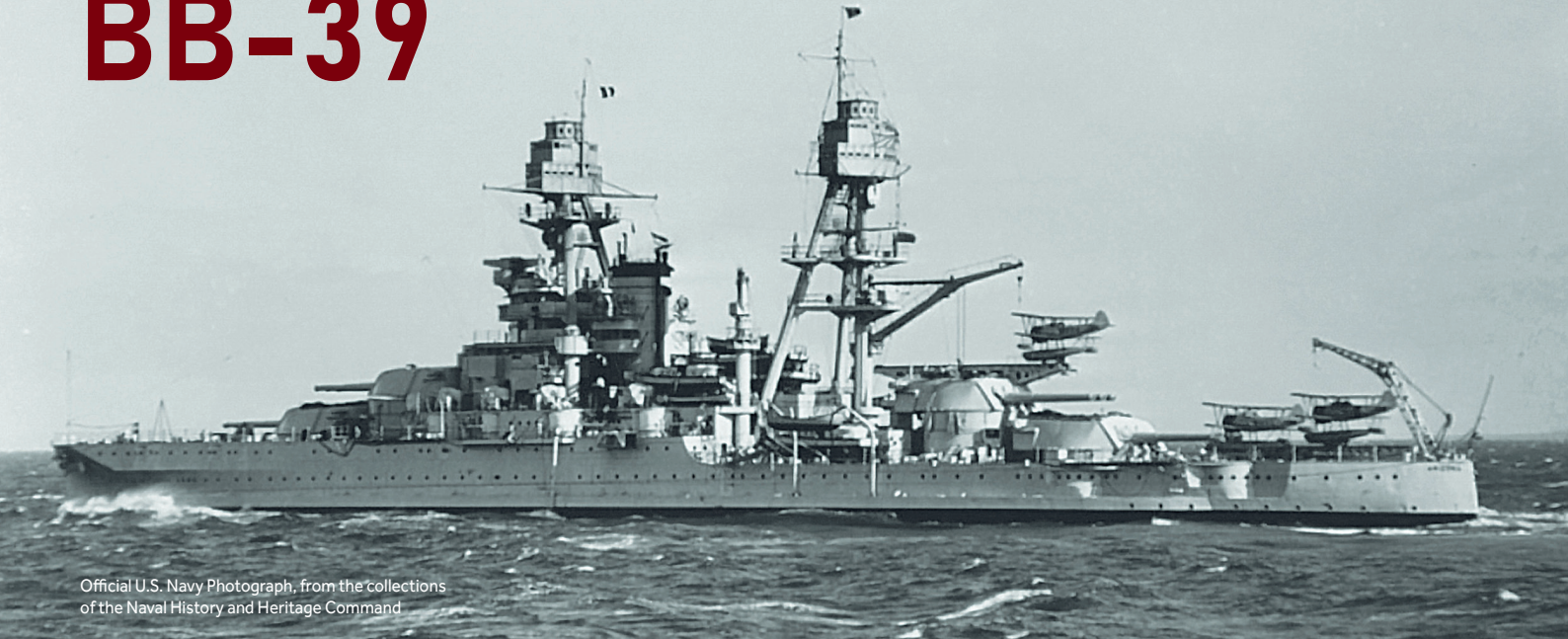

Official U.S. Navy Photograph, from the collections of the Naval History and Heritage Command

The keel of the Thirty-ninth Battleship of the United States Navy, the second unit of the Pennsylvania class, was laid in the morning of Monday, March 16, 1914, in the presence of Assistant Secretary of the Navy Franklin Delano Roosevelt, an up-and-coming thirty-two-year-old politician of the Democratic Party. A politician who, once President of the United States, would declare a state of war against the Empire of Japan in December 1941, just after the sinking of the battleship USS Arizona, which he had helped to create more than a quarter of a century earlier.

The name Arizona was chosen for the new battleship, designated BB-39, in keeping with the tradition of naming battleships after states of the Union. On Saturday, June 19, 1915, in the presence of 75,000 spectators and many honored guests, the USS Arizona was christened by Miss Esther Ross, daughter of William W. Ross, a pharmacist of Prescott, Arizona, who was instrumental in naming the ship. One bottle of traditional champagne from the vineyards of the State of Ohio, and one of water from Roosevelt Dam on the Salt River in Arizona, shattered against the bow shortly after one o'clock in the afternoon, and the massive hull of the battleship Arizona slid majestically to the surface of the East River.

The Pennsylvania class

The Pennsylvania-class battleships, BB-39 Arizona and BB-38 Pennsylvania were US Navy battleships falling into the superdreadnought category. The design of the Pennsylvania-class ships was based on that of the proven Nevada-class (BB-36 Nevada, BB-37 Oklahoma), but the Pennsylvania-class

was larger, with a displacement of 32,567 tons and an overall length of 608 feet (185.3 m) compared to the 28,400 tons and 583 feet (178 m) of the Nevada-class. Both classes had identical 14-inch (356 mm) caliber guns. The Nevada-class ships had three guns in the lower turrets and two in the higher turrets, for a total of 10 guns. The Pennsylvania-class ships increased their main armament to twelve 14-inch (356 mm) guns.

Propulsion

USS Arizona was powered by four Parsons steam turbines with a total output of 29,366 horsepower (21,898 kW). The steam was supplied by twelve Babcock & Wilcox fuel oil boilers in six boiler rooms. The turbines were driving four bronze propellers 12 feet, 1.5 inches (3.7 m) in diameter. The maximum amount of fuel carried was 2,342 tons, providing a range of just under 5,000 miles at 15 knots (28 km/h). The ship's design speed was set at 21 knots (39 km/h), and 21.5 knots was achieved during full power trials in 1924. Electricity was supplied by four 300 kW turbo-generators.

Armament

The main armament of the battleship *Arizona* consisted of twelve 14-inch (356 mm) Mk.3 L/45 guns, manufactured from 1910 by the U.S. Naval Gun Factory at the Washington Navy Yard. These guns were first used on New York-class battleships. Their maximum range was approximately 21,000 yards (19,278 m), and the maximum ammunition supply was 100 shells per barrel, for a total of 1,200 rounds. The guns were housed in a common bearing in the turrets, which was not a satisfactory option. If any gun in a turret was hit and damaged, the entire turret was thus out of action, i.e., 25 % of the ship's firing capacity.

Secondary armament consisted of 22-5-inch (127 mm) caliber guns in the Mk.15 L/51 version, 20 of which were mounted in armored casemates and the remaining two in unprotected positions on the sides of the conning tower. Their range was just over 14,000 yards (12,850 m). A supply of 230 shells was provisioned for each barrel, for a total of 5,060. Unfortunately, in heavy seas, the use of these guns was problematic to impossible. Two 3-inch (76 mm) Mk.21 L/50 guns were installed for anti-aircraft defense, and two more of these guns were fitted to gun turret number III shortly after commissioning. The ship also carried two 21-inch (533 mm) torpedo tubes with a supply of 24 torpedoes.

Armoring

The armoring of the US Navy battleships followed the "All or Nothing" system, which meant armoring vital parts of the ship and not armoring the rest at all. Armor protection was concentrated in the construction of the so-called citadel, a sort of armored box built into the ship's structure to protect her vital parts, especially the main artillery's guns and ammunition stores, propulsion and control systems, and the ship's essential points of command. The armor protection was made of Krupp type alloy steel, with a 13.5-inch (343 mm) thick side armor belt total 5.3 meters high (in which 2.6 meters were under the waterline and

the rest over the waterline) protecting the engine rooms and ammunition magazines. It was enclosed at both ends by armor bulkheads of variable thickness from 8 to 13 inches (203 to 330 mm). The three-plate armored deck was 3 inches (76 mm) thick, increased to 6.25 inches (159 mm) at the steering gear. Below this was another deck (splinter deck) 1.5 to 2 inches thick. A 9 to 15 inches (228 to 381 mm) thick armor plate protected the steam and boiler intakes. The most heavily armored parts of the ship were the gun turrets, the barbettes and the conning tower. The faces of turrets were protected by 18 inches (457 mm) of armor, with sides by 9-10 inches, and with ceilings by 5 inches (127 mm) of armor plate. The conning tower was protected by 16-inch (406 mm) thick steel plates, and the roof was 8 inches thick. The ship's double bottom was designed to withstand the explosion of a 300 lb (140 kg) TNT charge.

Mast

The hallmark of all US battleships of that era was the visually distinctive lattice-weave masts, known in contemporary terminology as cage masts. This name well describes the shape and structure of their construction.

Enlistment in the US Navy

USS *Arizona* was commissioned into the U.S. Navy on 17 October 1916 with John Mc Donald as her first captain. On 10 November she sailed from New York with a crew of 56 officers and 1,031 enlisted men for her first so-called shakedown cruise, testing the ship's performance and the correct operation of all machinery. Unfortunately, during the cruise near Guantanamo Bay, Cuba, one of the turbines was found to be damaged. *Arizona* therefore returned to the New York shipyards for repairs to the turbine, accompanied by the necessary replacement of the damaged components. After nearly four months, the ship was ready to sail again and left the shipyards on April 3, 1917.

In the East River, New York City, at the time of her trials, circa mid-1916. She is accompanied by many tugs and has small pine trees mounted in her mast tops. Tug Hudson is in the lower center.



Photographed by Enrique Muller, Jr. ; Courtesy of Sid Taylor, 1983

Steaming in formation with other Atlantic Fleet battleships during gunnery practice, circa 1917.

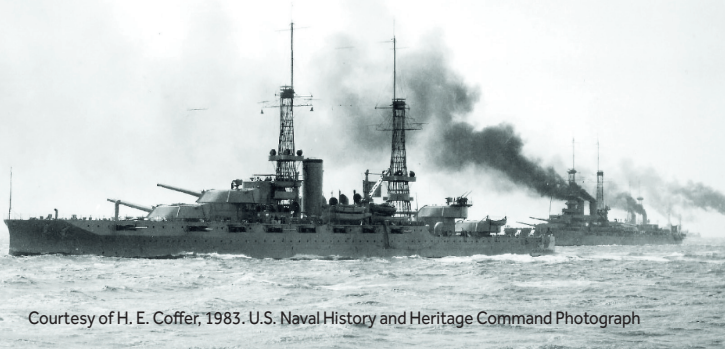

Courtesy of H. E. Coffey, 1983. U.S. Naval History and Heritage Command Photograph

World War I

On April 6, 1917, the United States declared war on the German Empire, and a week later the USS Arizona was assigned to the 8th Battleship Division operating near New York City. Due to the freshness of her assignment to the fleet and her crew's pending training, the ship only conducted gunnery drills for her own crew and gunners preparing for service on armed merchant ships assigned to convoys sailing across the Atlantic to the Europe. Here the advantage of the unification of the US Navy's artillery armament is quite illustrative, where gunners could train on any vessel armed with a given weapon and then serve

on any ship on which that weapon was fitted. Shortly after Arizona's assignment to the 8th Division, eight 5-inch (127 mm) guns were removed and fitted to newly armed merchant vessels, as there was an acute shortage of these guns at the time of the U.S. entry into the war. These guns were never returned to the Arizona, partly because of their low combat value in high water during the war.

A training area in Tangier Sound in the east Chesapeake Bay south-east of Washington DC was used for practice firings. The wreck of the USS San Marcos (ex USS Texas, a pre-dreadnought battleship built in the early 1890s) had been sunk in the shallow part of the bay since March 1911 as a target ship, where gunners practiced firing the main battery of 14-inch guns. Otherwise, USS Arizona's early wartime life was fairly uneventful, with no major sailings further out into the Atlantic, among other reasons, because there were fears of German U-boat attacks. Although December 1917 saw the deployment of the four battleships making up the 9th Battleship Division to Britain, Arizona was not among them. Despite, or perhaps because of, the fact that the ship practically only drilled and trained, in July 1918 the sailors of the Arizona won the prestigious Battenberg Cup for cutter warship rowers, beating the rowers of the Nevada by a full three lengths on a three-mile course in the final.

Post-war service

A week after the end of World War I, the USS Arizona embarked on her maiden trans-Atlantic ocean voyage to join nine other battleships and 28 destroyers near Brest on December 13, 1918 as escort to the ocean liner George Washington, carrying United States President Woodrow Wilson to the peace talks in Paris. The fleet was back in New York on December 26, 1918. For the next few weeks, the USS Arizona remained docked and was open to the public.

Pitching in heavy seas during the 1930s...



Official U.S. Navy Photograph, now in the collections of the National Archives.

In April 1919 she sailed again for Europe to accompany President Wilson on his voyage back to the U.S. from the Versailles Peace Conference. However, in response to current political tensions between Greece and Turkey, she moved to Izmir, Turkey. After the fighting between the Turks and Greeks ended, she sailed to Istanbul where she started her journey home on June 15, 1919. Upon her return to New York on June 30, 1919, she underwent an overhaul, during which six 5-inch (127 mm) guns were removed and the fire control system was modernized. By January 1920 USS Arizona was fitted with an experimental takeoff platform on the gun turret. In August 1920 she became the flagship and admiralty ship of the 7th Battleship Division. In early 1921, after completing joint Pacific and Atlantic Fleet maneuvers associated with a visit to Peru, she underwent another refit at the New York Shipyards. After which she moved to her new homeport at San Pedro, California, which remained her home until 1940.

Conversion and modernization

In January 1929 Arizona underwent a radical rebuild at the Norfolk shipyards in Virginia. As a result of the conclusions of the Washington Naval Conference all the major fleets of the world began rebuilding anything that had at least some combat potential for the coming years. A major factor transforming the appearance, equipment, and armament of warships was the increasingly powerful naval aviation. On board Arizona the obsolete cage masts were replaced by tripod masts on which modern fire control elements were mounted. The number of the original 5-inch (127 mm) guns was reduced to 12, the guns were relocated one deck above, and eight new 5-inch (127 mm) semi-automatic anti-aircraft guns were added. The gun turrets of the main artillery were modified to an elevation of 30°, which increased the range to a limit of 31 km. The compressed air catapult was replaced by a gunpowder-powered catapult. The deck received additional armor of 1.75 inches (44 mm) and the hull got a bulky anti-torpedo plating, which, while increasing protection against torpedoes, resulted in a reduction in maximum speed. This conversion also saw the complete removal of the torpedo tubes and their accessories.

The engine room was also upgraded by replacing the original high-pressure turbines with modern Westinghouse turbines from the decommissioned and cancelled new ship USS Washington. The old boilers were replaced with six Bureau-Express boilers. The total output of the upgraded engine room rose to 35,081 horsepower (26,160 kW), compensating for the increased displacement of the ship. The ship's top speed was still a very respectable 20.7 knots, and her range was 13,600 miles at 15 knots. The size of the funnel was also modified, and the funnel was moved slightly to the rear during this change.

The Thirties

Beginning March 19, 1931, a modernized Arizona hosted President Hoover on his vacation in the Caribbean. Upon the President's return to land on March 29, 1931 she passed full naval tests and subsequently an additional catapult was installed on Tower III. In February 1932 Arizona participated in a major Pacific Fleet exercise when she was part of the group of ships that successfully attacked Pearl Harbor, Hawaii. In March 1933 she participated in rescue efforts following the earthquake that struck Southern California on March 10, and in 1934 she and the airship USS Macon starred in the movie *Here Comes the Navy*, with James Cagney in the lead role.

On July 26, 1934, she collided with the trawler Umatilla off the rocky Cape Flattery (Neah Bay, Washington State, north-west of Seattle). Another accident occurred during a gunnery exercise on July 1936, when hot fumes from a cannon shot in turret number II got back into the gun turret. After the fire extinguishing system was started, the water caused a short circuit in the turret wiring which resulted in a small fire that was fortunately soon extinguished.

In 1936-37 federal budget cuts took full effect. At that time the USS Arizona was docked for a full 267 days, and 255 days the following year. In April-May 1938, as part of the 1st Battleship Division, she participated in the major exercise „Fleet Problem XIX“ near the Hawaiian Islands. On September 17, 1938, Rear Admiral Chester W. Nimitz assumed command of the 1st Battleship Division and was relieved by Rear Admiral Russell Wilson on May 27, 1939.

From May 1940 the U.S. Navy's Pacific Fleet was permanently stationed in Hawaii due to growing tensions with Japan. USS Arizona underwent her last major refit and modernization from October 1940 to January 1941 at Pudget Sound Navy Yard in Seattle, Washington, consisting of, among other things, the insta-

llation of a base for a search radar (which was not installed) on the foremast. In addition, the fire control system was upgraded and a platform for four 0.5-inch (12.7 mm) Browning M2 water-cooled anti-aircraft machine guns was installed at the very top of the main foremast. The ship then sailed back to her home base at Pearl Harbor, Hawaii.

Japanese attack on Pearl Harbor

At 7:55 a.m. on Sunday, December 7, 1941, an anti-aircraft alert was sounded on the USS Arizona. By then B5N2 Kate bombers of the first attack wave were already attacking her, each one carrying a 800 kg bomb. Five Kates from the aircraft carrier Kaga attacked from an altitude of 3,000 meters towards the stern from amidships, a little later one of the five bombers from the aircraft carrier Hiryu scored a hit on the bow. Arizona scored four direct and three close-in hits. At 8:06 Hawaiian time she took a fatal hit near turret number II. The bomb penetrated the armor deck and exploded in the ammunition magazines on the bow. The huge blast destroyed the bow and caused the forward turret to drop nine meters inside the hull. The foremast collapsed forward, and the hull was torn in half. The fires caused by this explosion raged for two full days. The destroyed Arizona grounded on the sandy bottom of a bay near Ford Island. The attack killed 1,177 sailors and officers out of a total crew of 1,512.

Over the following months the surviving armament was removed and carried ashore. The rear gun turrets were removed and, after a thorough cleaning and necessary repairs, were prepared for mounting as a battery of coastal artillery, which ultimately did not happen. The forward gun turrets remained in the wreck, but the usable main caliber guns were removed and, after repairs in the fall of 1944, mounted on the battleship USS Nevada, which was repaired and returned to service after the attack on Pearl Harbor. As a result, the Arizona's guns supported the landing of American troops on Iwo Jima and Okinawa in the spring of 1945.

Arizona forever

After the war it was decided to leave the remains of the Arizona at the site of the sinking. Through the efforts of Presidents Eisenhower and Kennedy, the wreck was declared a national shrine and a memorial was built over it to the victims of the Japanese attack on Pearl Harbor and all the fallen US Navy personnel killed during World War II. The ship is administered by the National Park Service and has never been decommissioned by the US Navy.

The USS Arizona's ship's bell still hangs on the campus of the University of Arizona in Tucson. Located in the Student Union Memorial Center, the bell rings whenever the home football team defeats an opponent, except when another Arizona team is defeated.

View taken on December 10, 1941, at Pearl Harbor, Hawaii, showing the ship sunk at her moorings as a result of the Japanese attack. Ships in the background include (from left to center): USS Tangier (AV-8), USS Solace (AH-5), a Brooklyn class light cruiser, and the hulk of the old minelayer USS Baltimore (CM-1).



Courtesy of the Naval Historical Foundation, Forrester Collection, 1975
U.S. Naval History and Heritage Command Photograph



Carefully read instruction sheet before assembling. When you use glue or paint, do not use near open flame and use in well ventilated room. Keep out of reach of small children. Children must not be allowed to suck any part, or pull vinyl bag over the head.



Před započítím stavby si pečlivě prostudujte stavební návod. Při používání barev a lepidel pracujte v dobře větrané místnosti. Lepidla ani barvy nepoužívejte v blízkosti otevřeného ohně. Model není určen malým dětem, mohlo by dojít k požití drobných dílů.

INSTRUCTION SIGNS * INSTR. SYMBOLS * INSTRUKTION SINNBILDEN * SYMBOLES * 記号の説明



OPTIONAL
VOLBA



BEND
OHNOT



SAND
BROUSIT



OPEN HOLE
VYVRTAT OTVOR



SYMETRICAL ASSEMBLY
SYMETRICKÁ MONTÁŽ



REMOVE
ODŘÍZNOUT



REVERSE SIDE
OTOČIT



APPLY EDUARD MASK
AND PAINT
POUŽIT EDUARD MASK
NABARVIT

PARTS



DÍLY



TEILE



PIÈCES



部品

PE - PHOTO ETCHED DETAIL PARTS

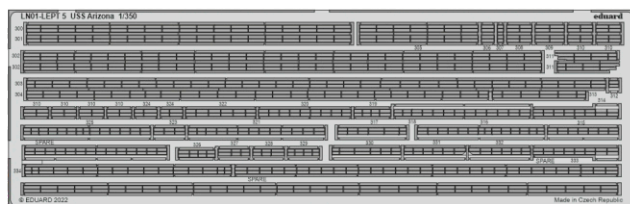
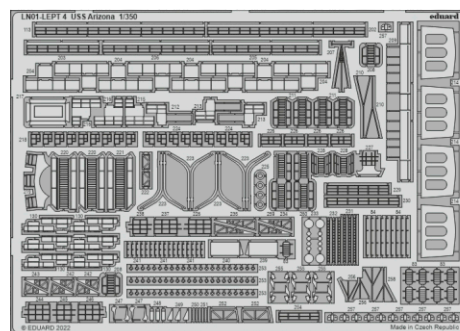
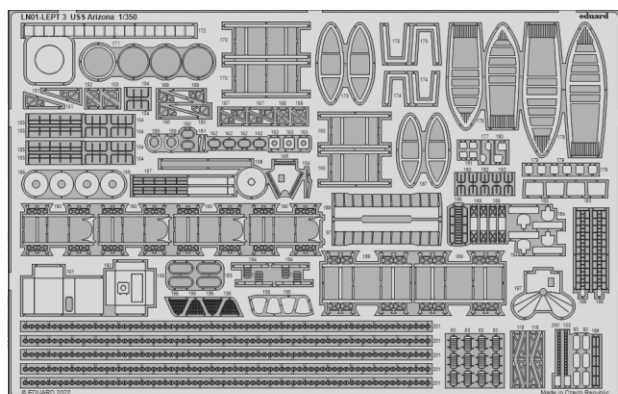
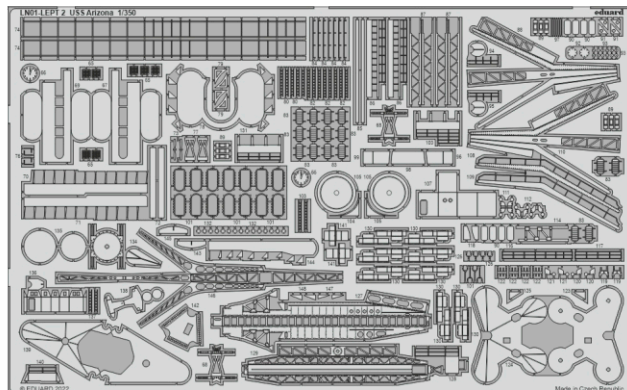
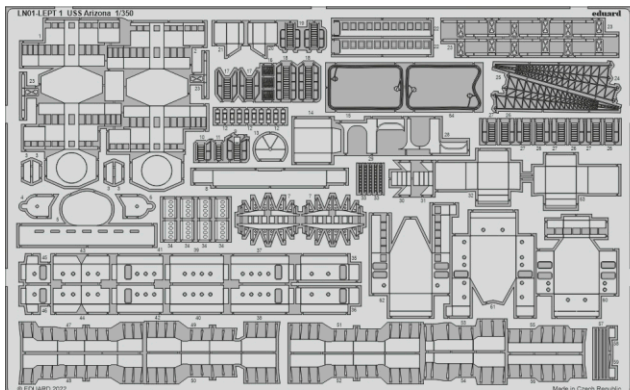

MP - MASTER PARTS



MP1
8 pcs.



MP2
10 pcs.

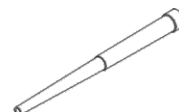

MP3
12 pcs.

RP - RESIN PARTS



R1
8 pcs.

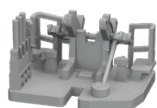

R2
8 pcs.



R3
8 pcs.



R4
2 pcs.



R5
16 pcs.



R6



R7



R8
3 pcs.



R17
2 pcs.



R9
4 pcs.



R10
6 pcs.



R11
6 pcs.



R12



R13
4 pcs.



R14
3 pcs.



R15
2 pcs.



R16



PLASTIC PARTS

A> 2 pcs.

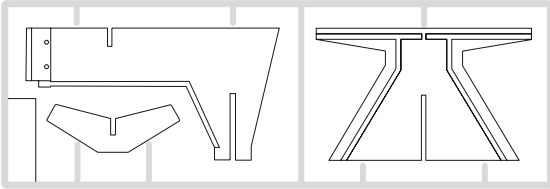

B>

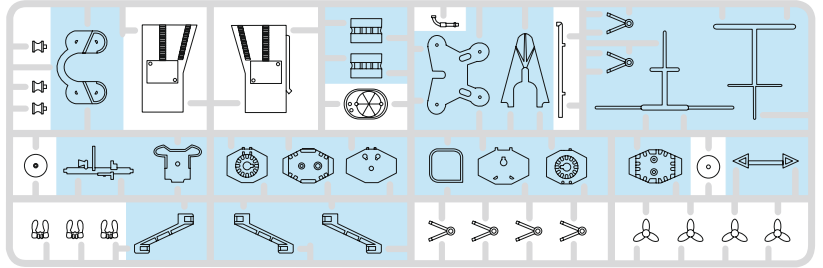

C>

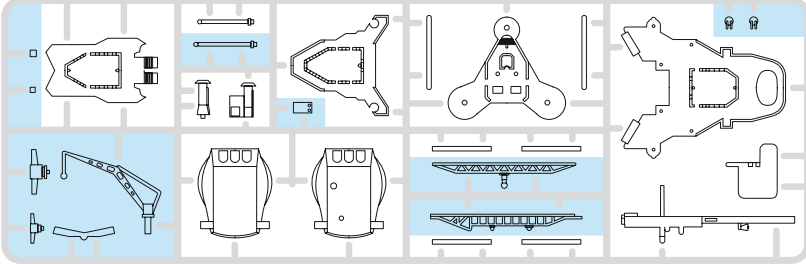

D> 2 pcs.

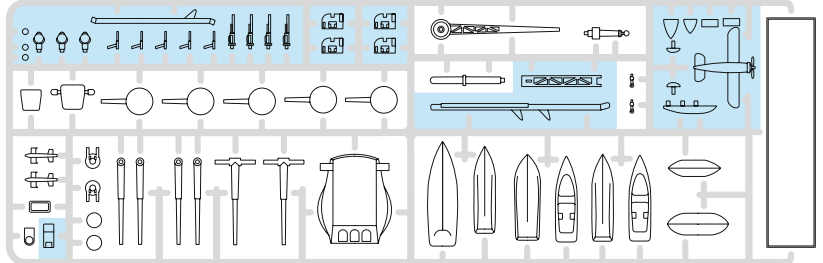

Rear deck

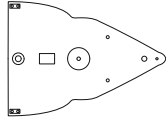

Fore deck

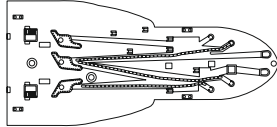

Center deck

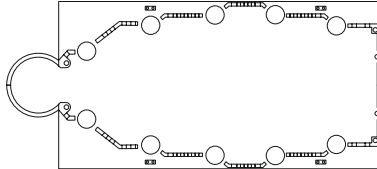

Upper deck

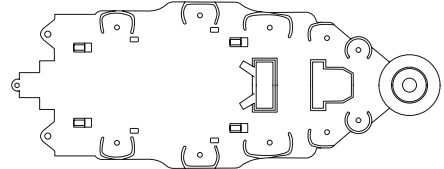

Upper hull

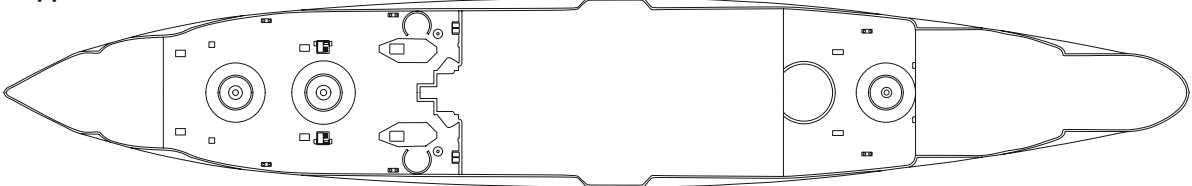

Lower hull



-Parts not for use. -Teile werden nicht verwendet. -Pièces à ne pas utiliser. -Tyto díly nepoužívejte při stavbě. - 使用しない部品



GSI Creos (GUNZE)		MISSION MODELS	
AQUEOUS	Mr.COLOR	PAINTS	
H11	C62	MMP-001	FLAT WHITE
H12	C33	MMP-047	FLAT BLACK
H37	C43		WOOD BROWN
H56	C366	MMP-071	INTERMEDIATE BLUE
H325	C325	MMP-063	GRAY

GSI Creos (GUNZE)		MISSION MODELS	
AQUEOUS	Mr.COLOR	PAINTS	
H328	C328		BLUE
H338	C338	MMP-116	LIGHT GRAY
H414	C114	MMP-003	RLM23 RED
	C367	MMP-061	BLUE GRAY

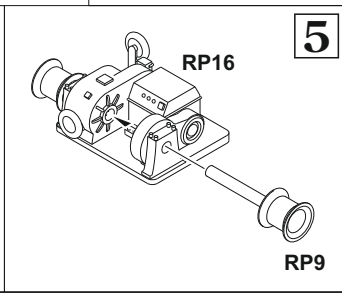
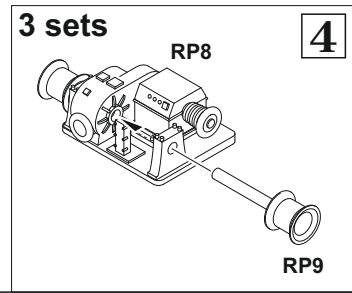
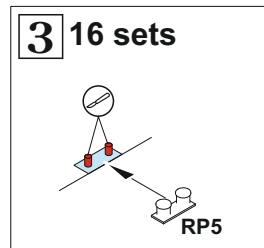
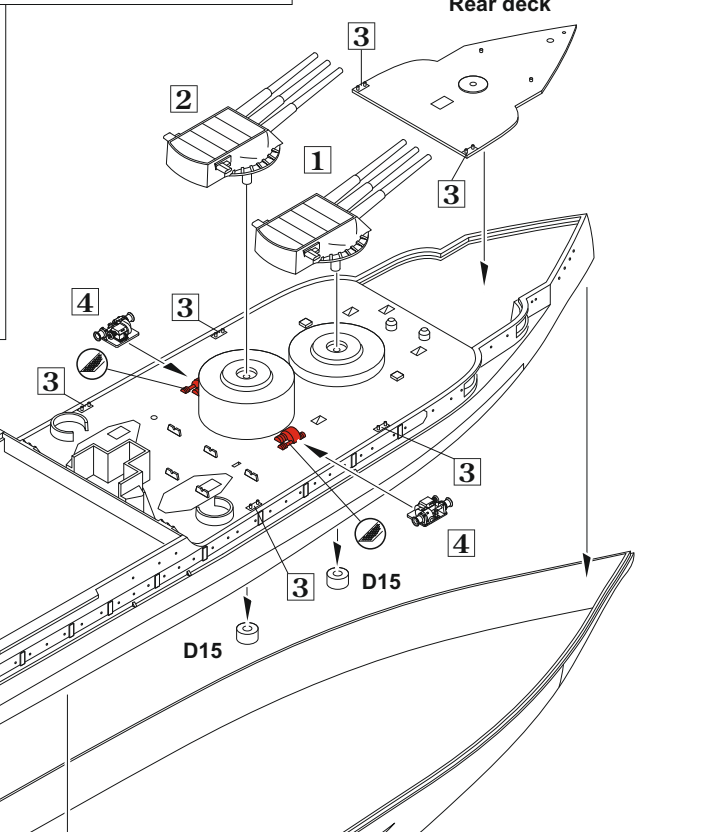
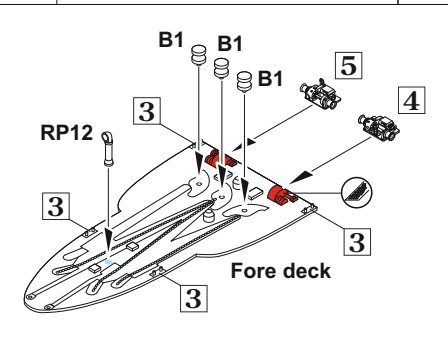
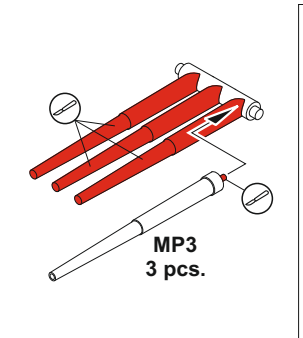
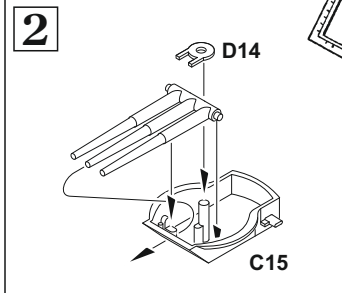
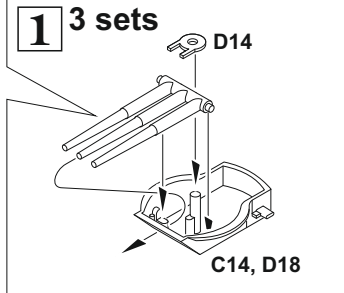
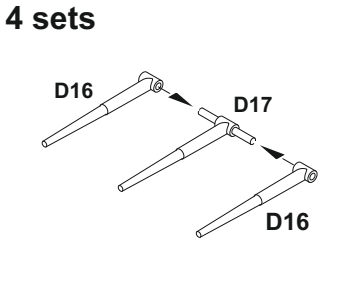
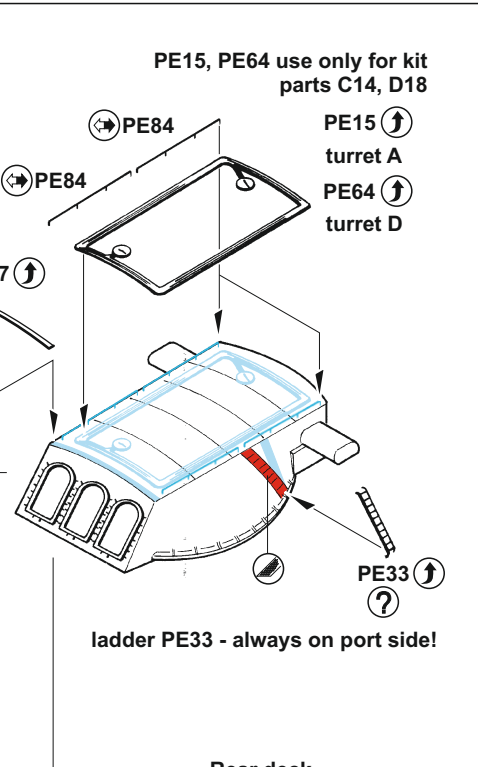
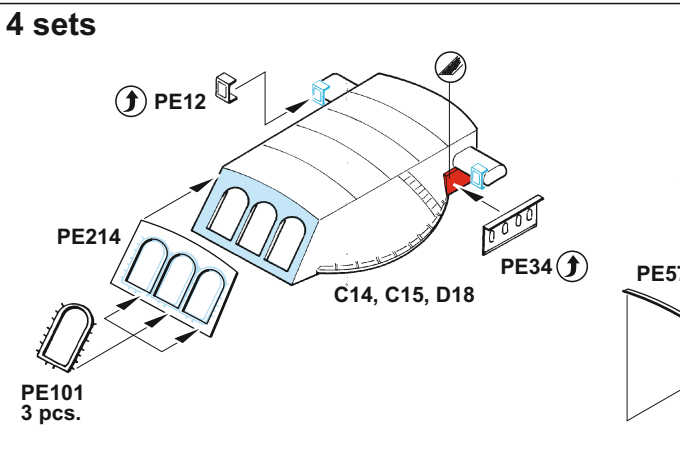
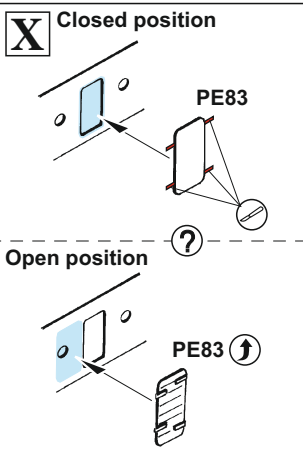

6 2 sets

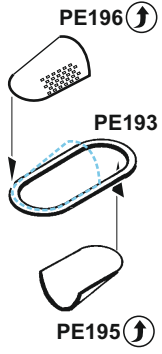

7 3 sets

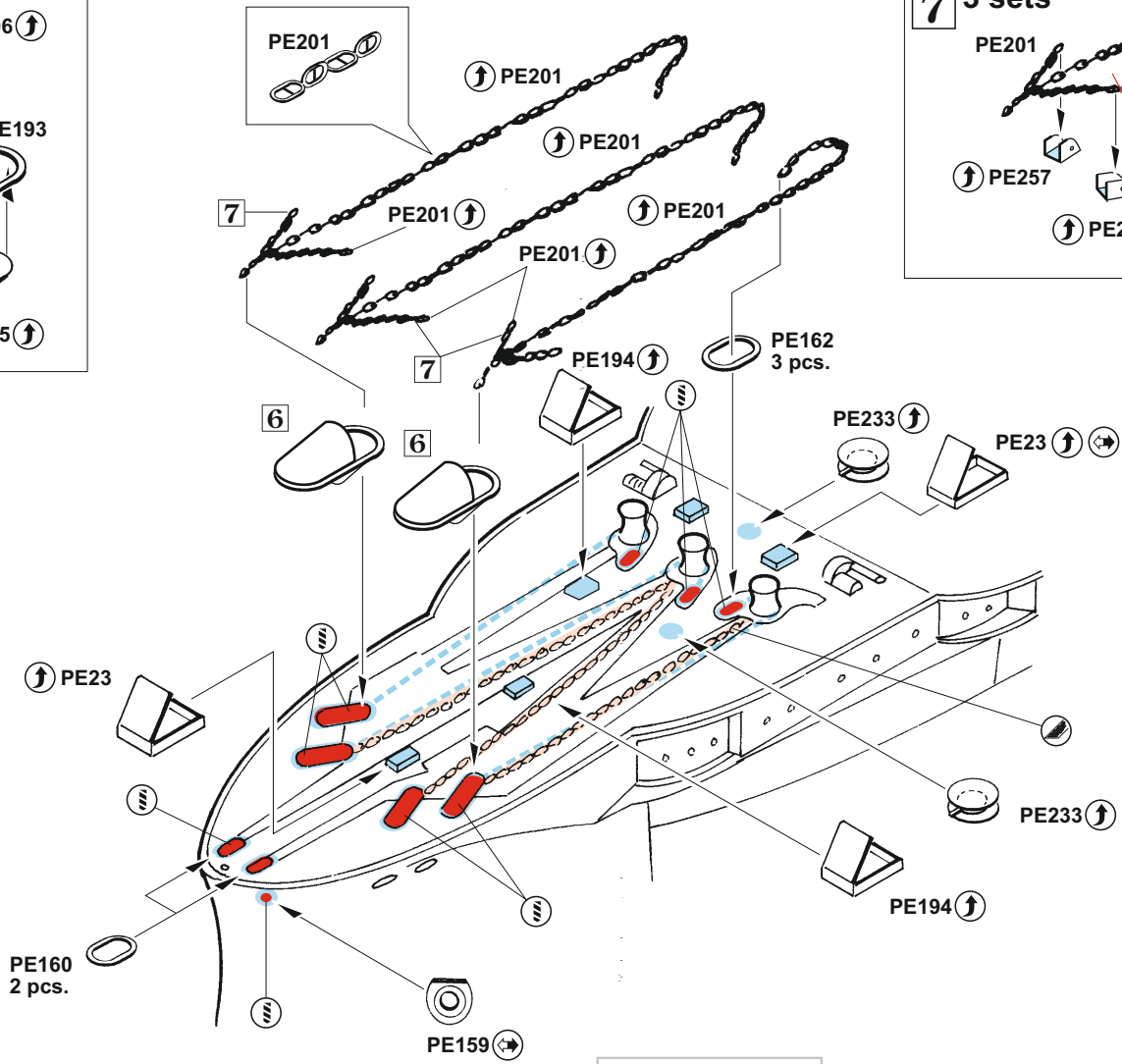
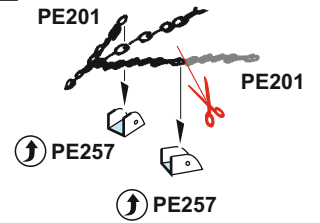

PE21 PE20

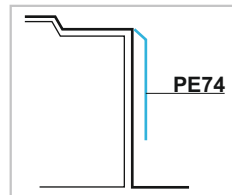
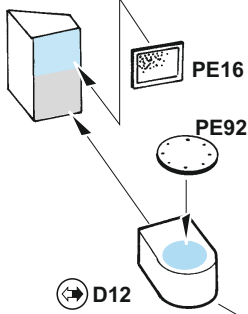

8

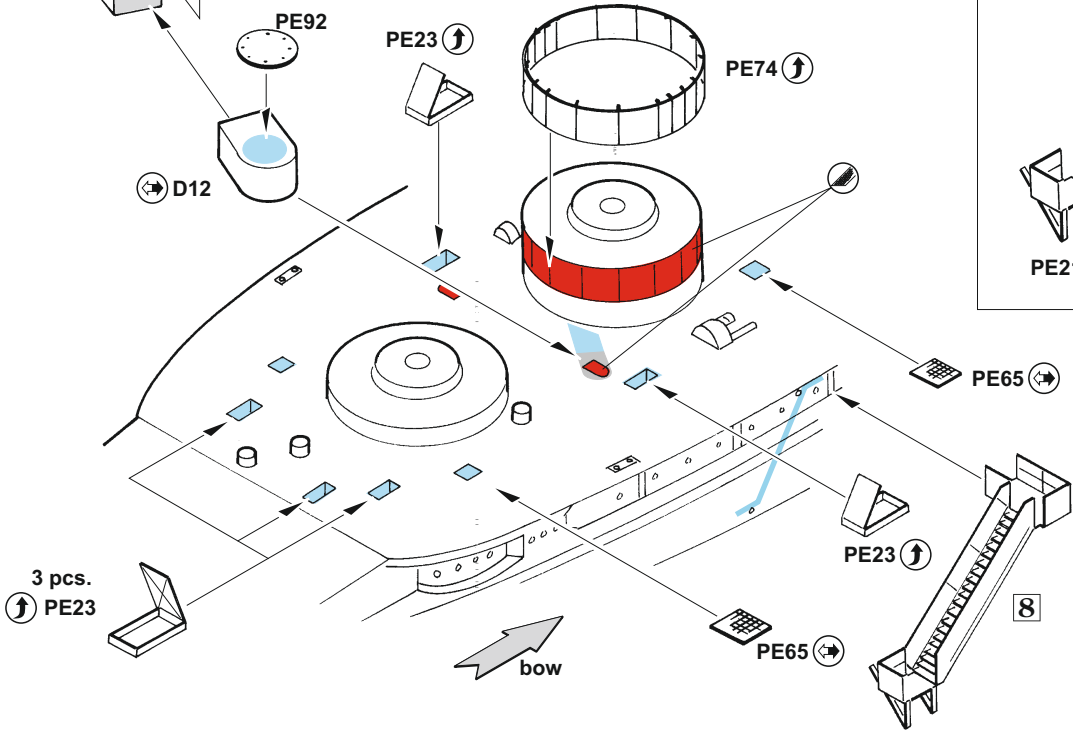
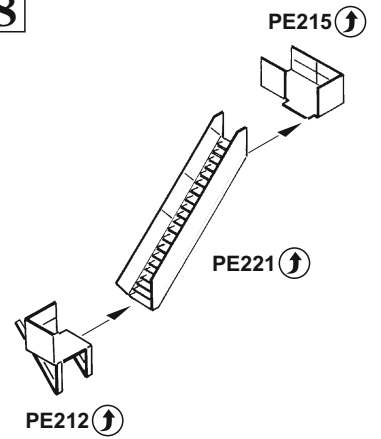

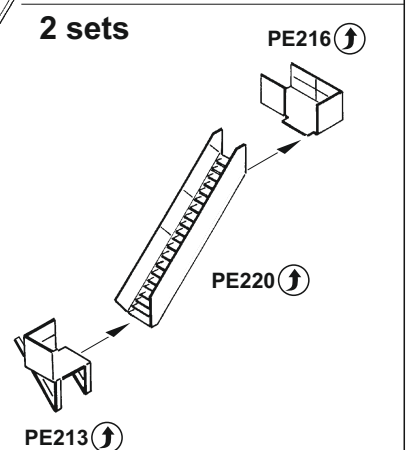
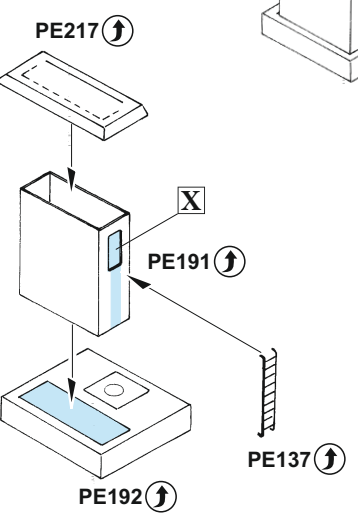
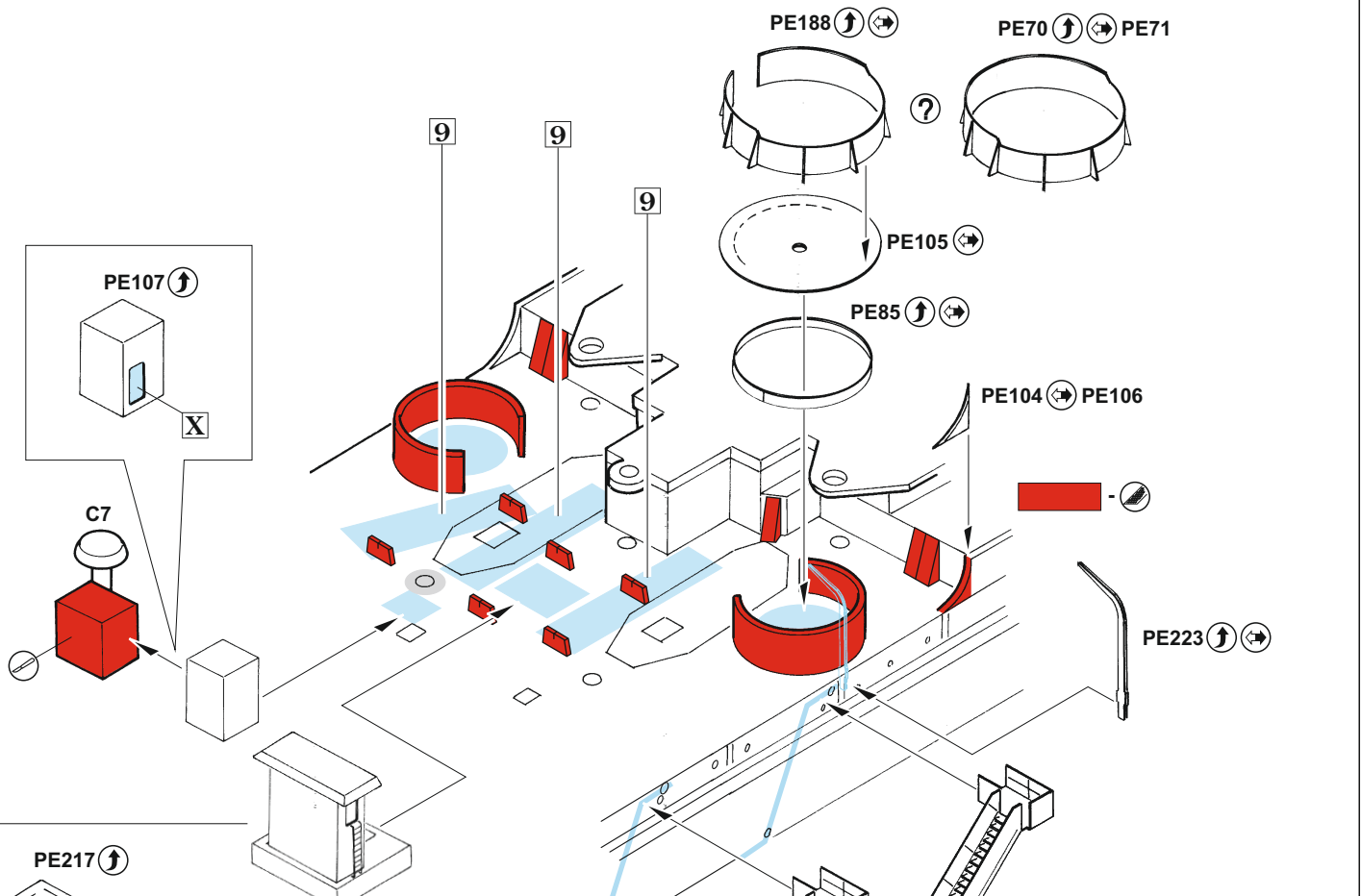
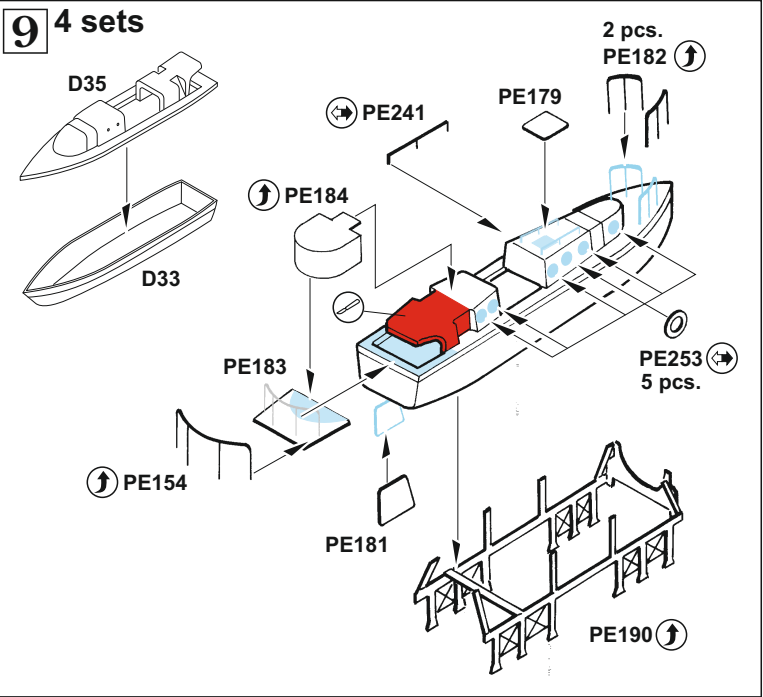
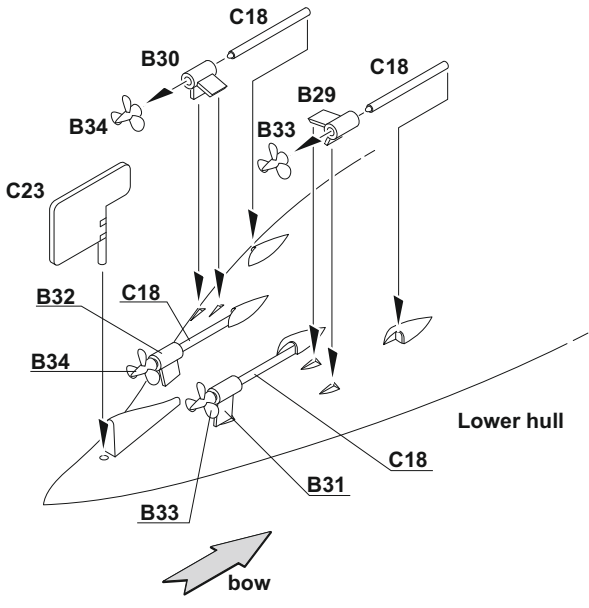

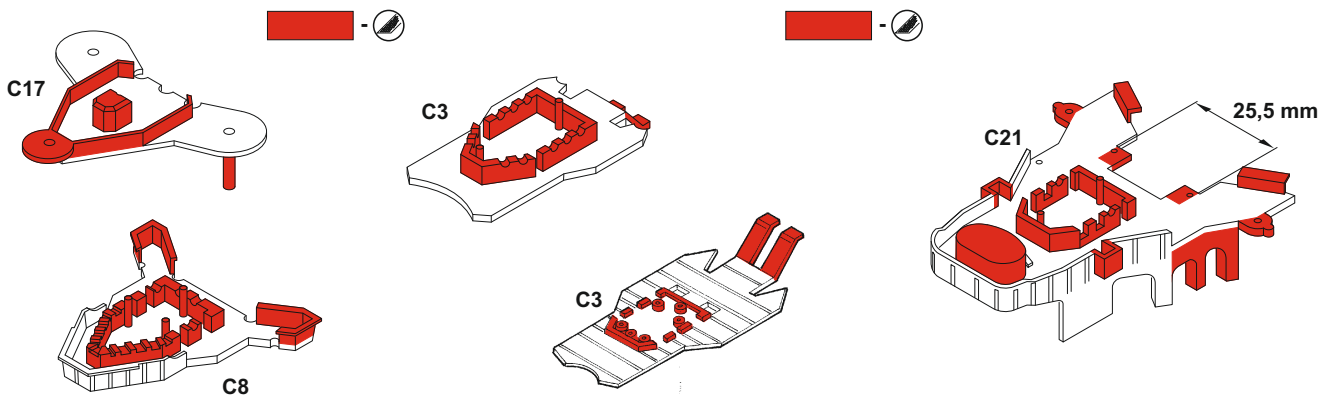
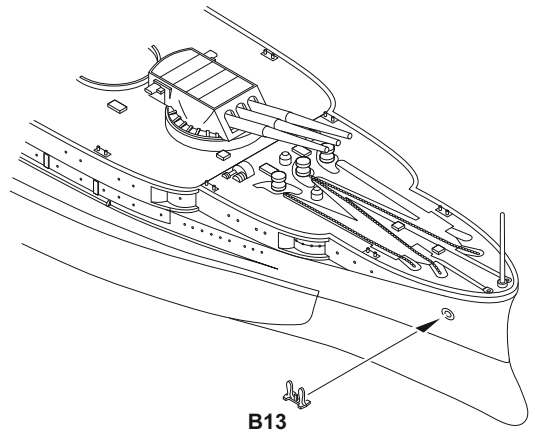
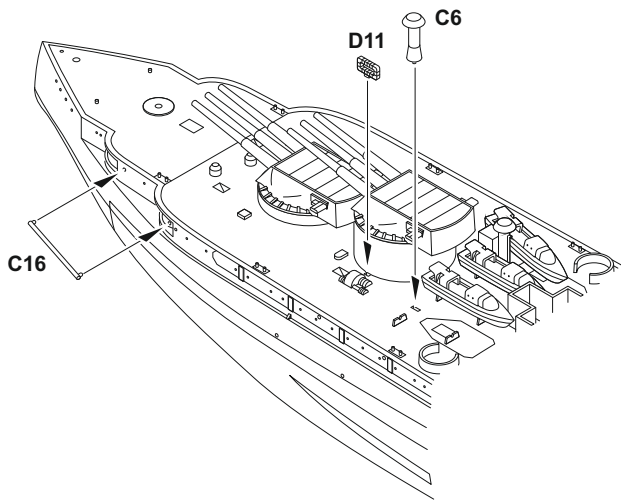
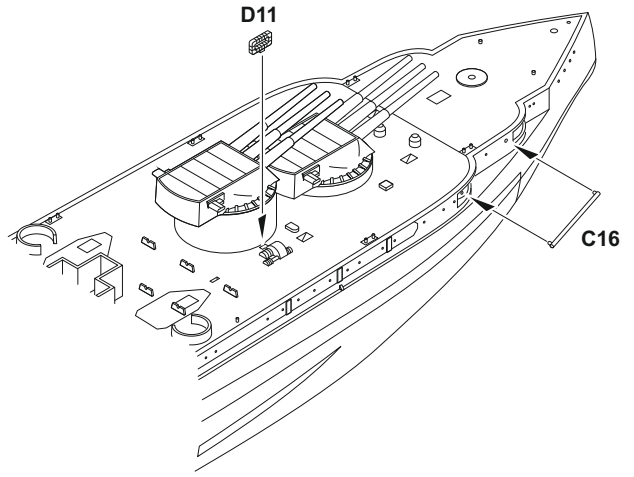
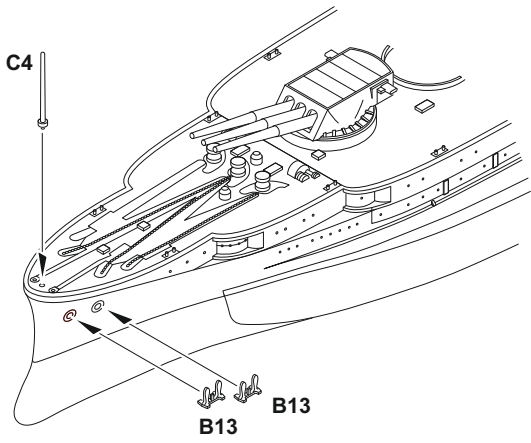

10 2 sets

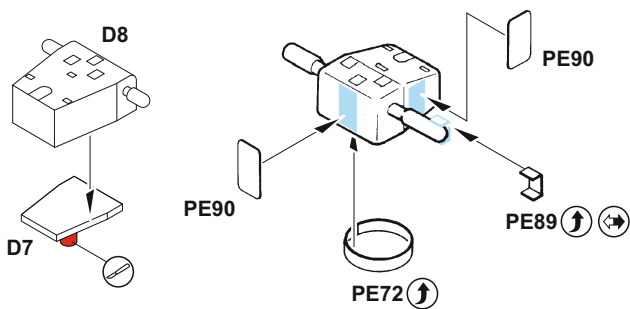

11

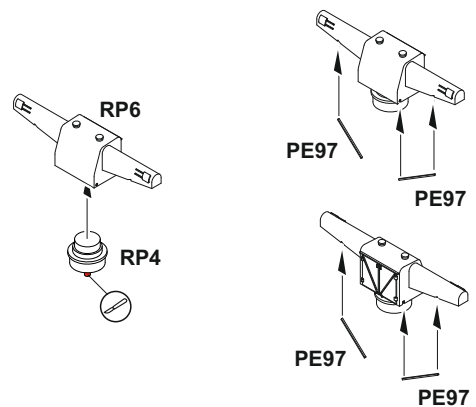

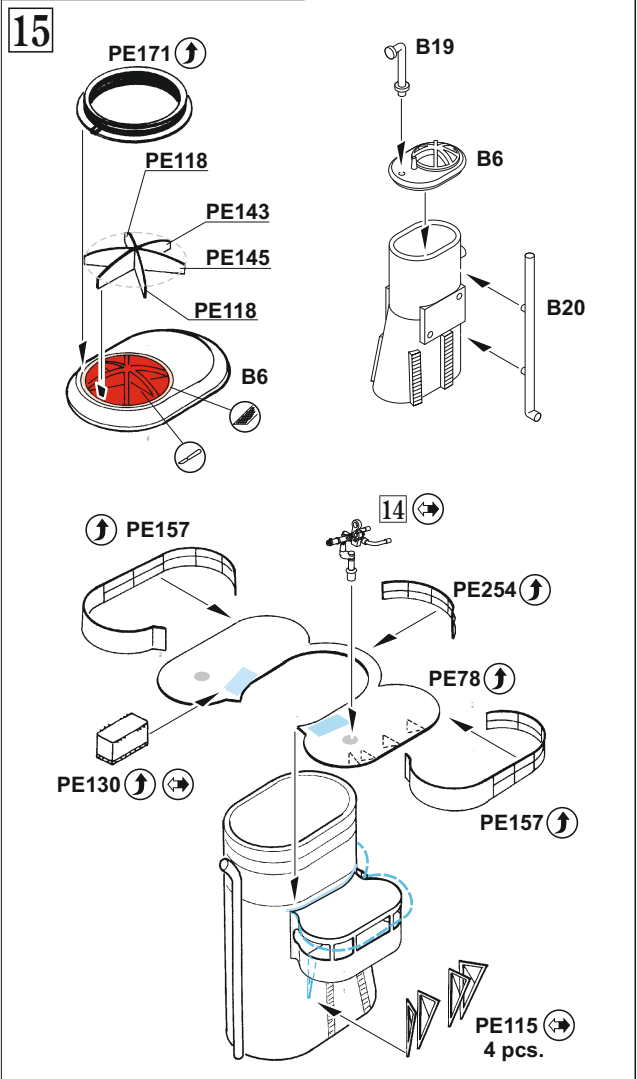
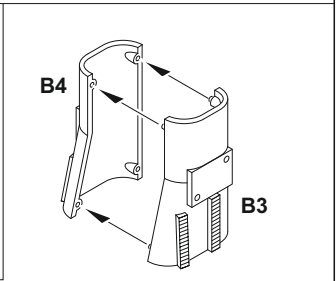
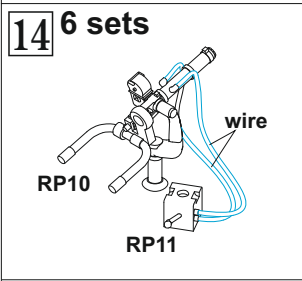
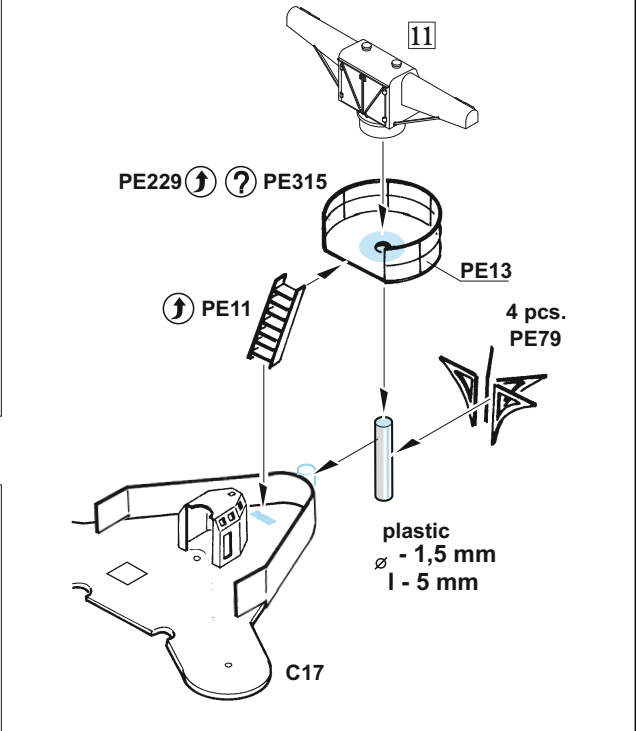
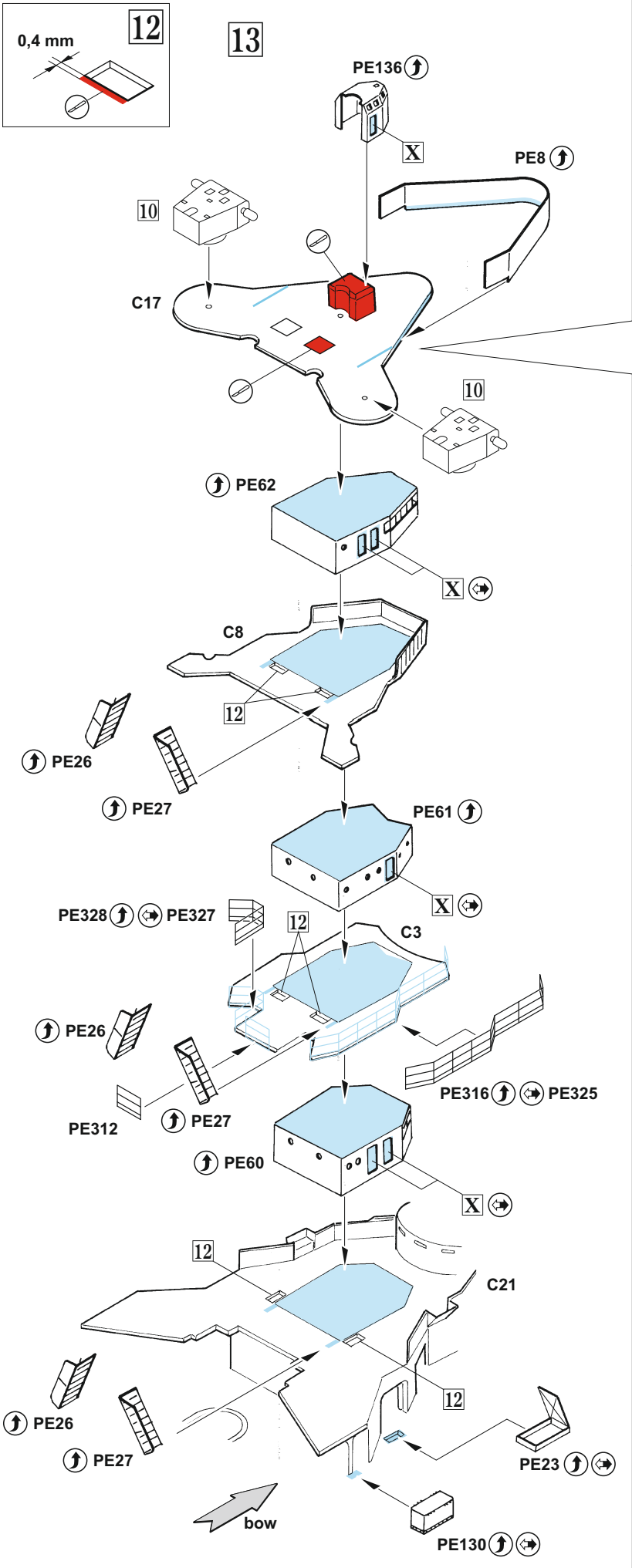

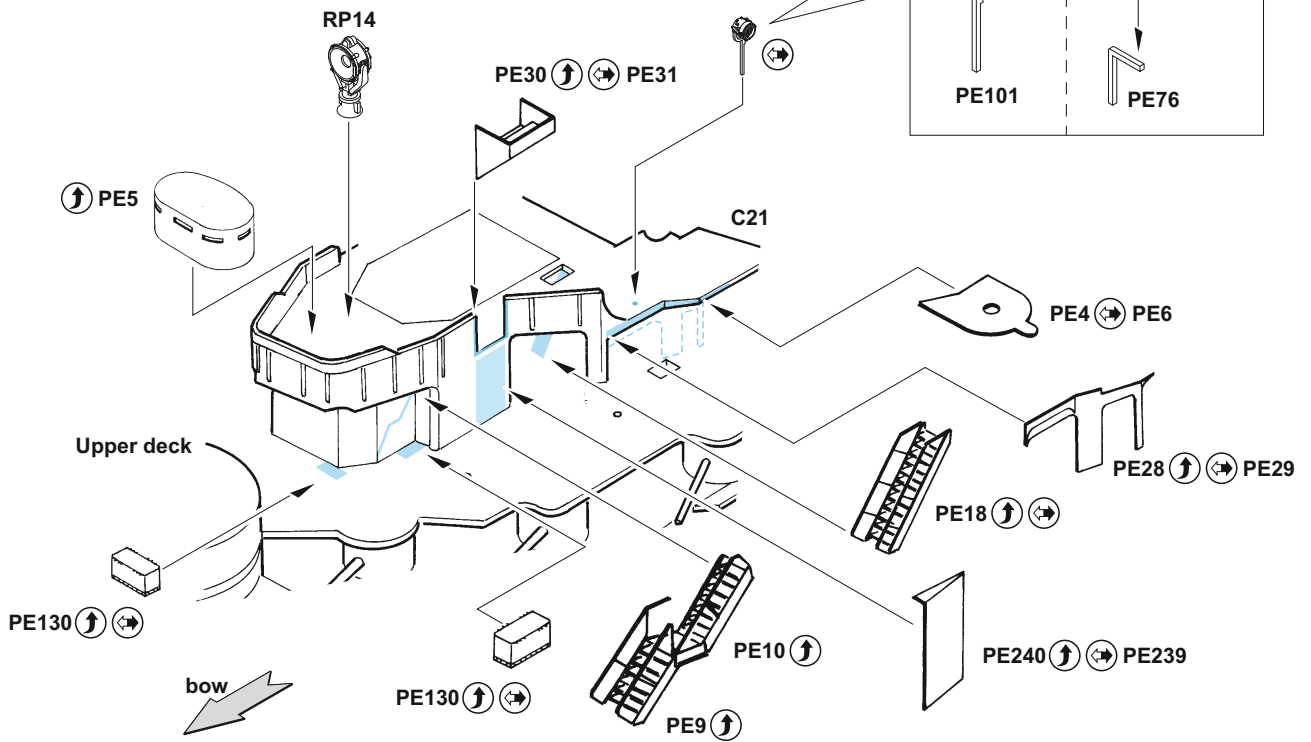
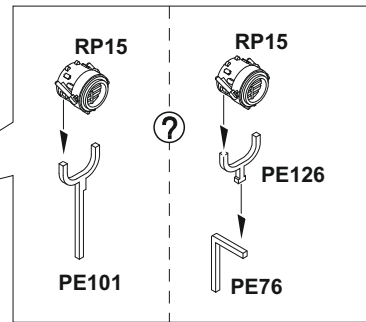
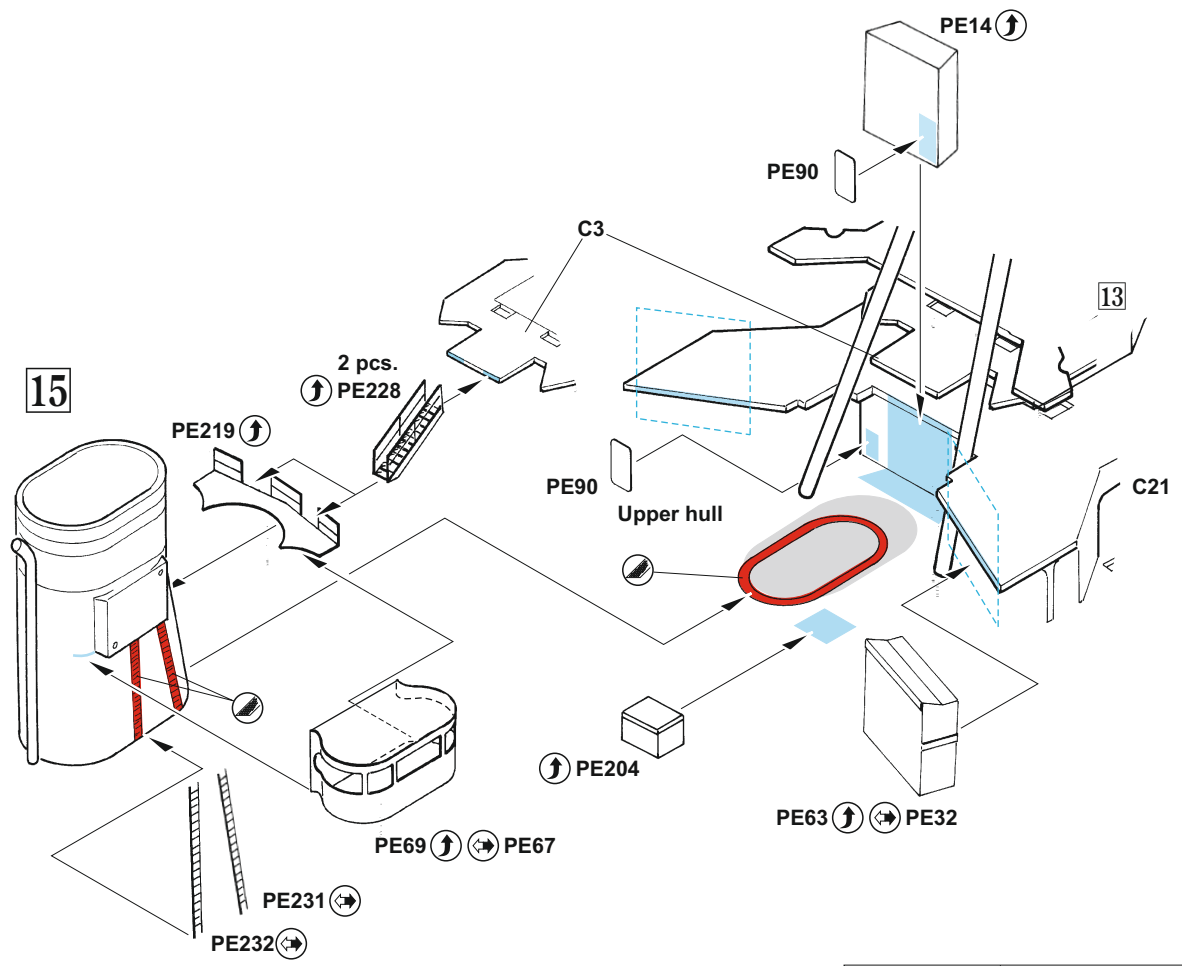

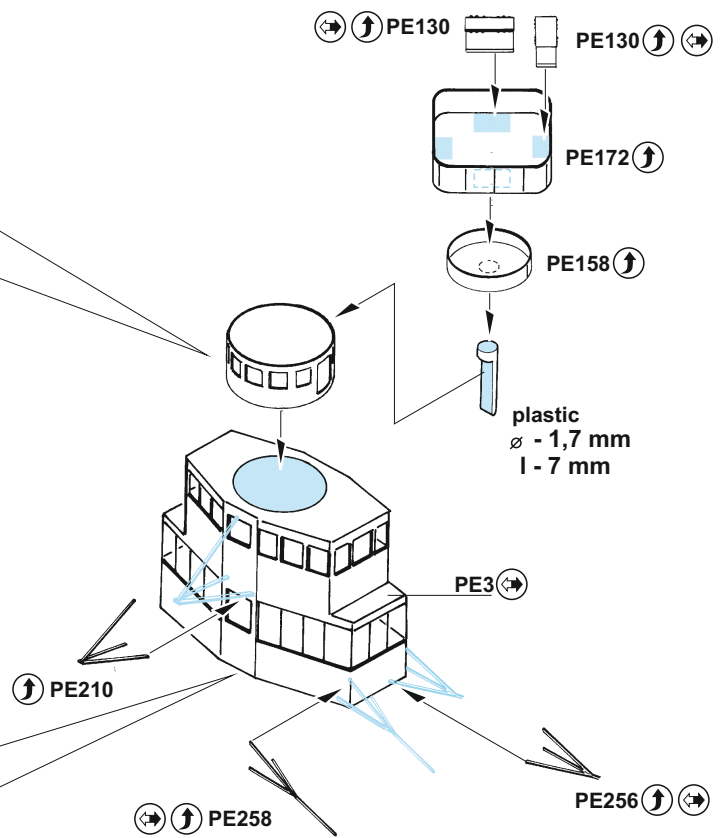
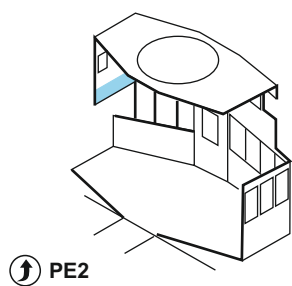
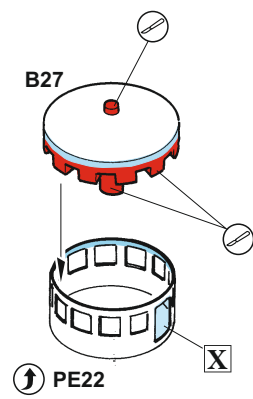
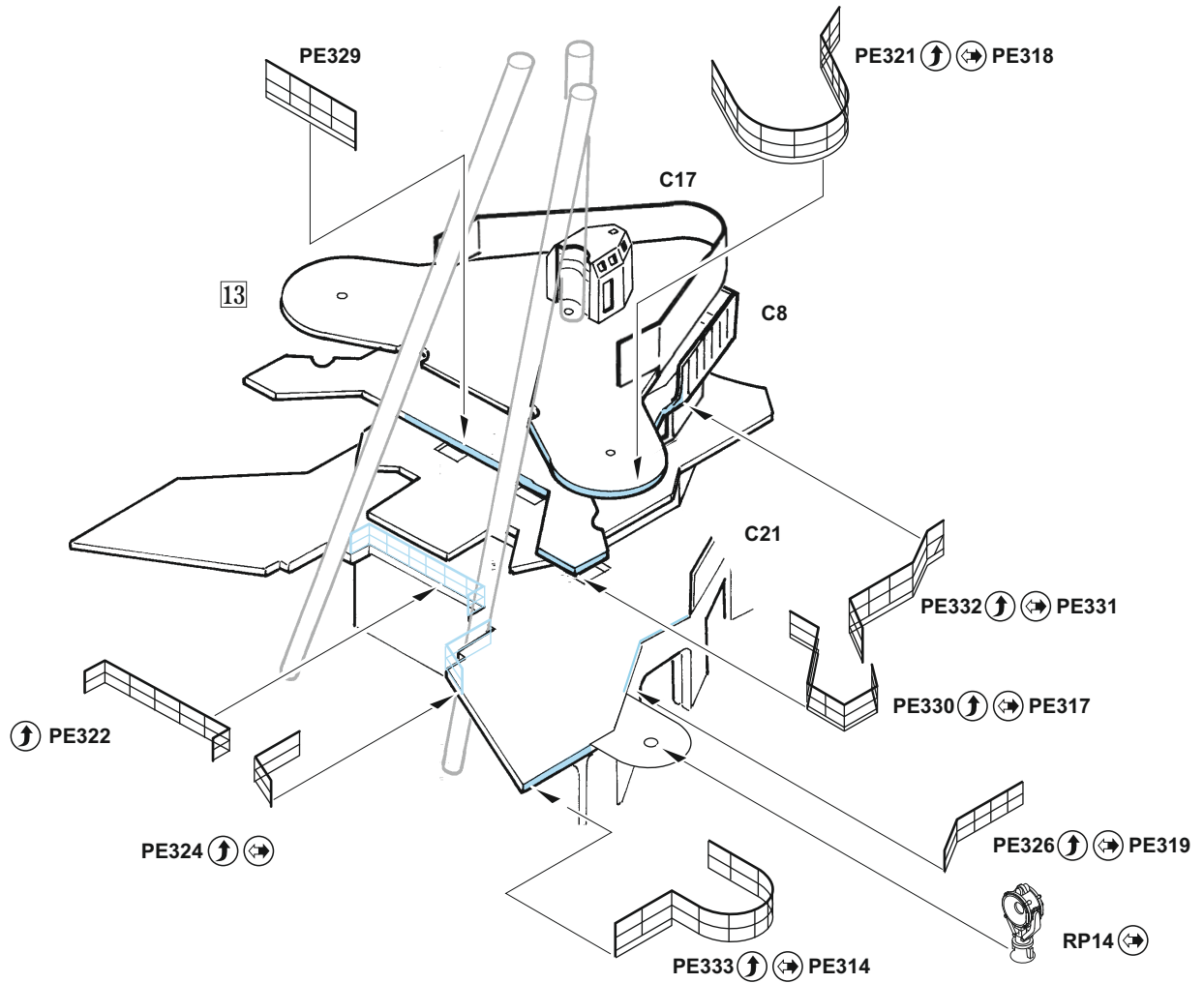

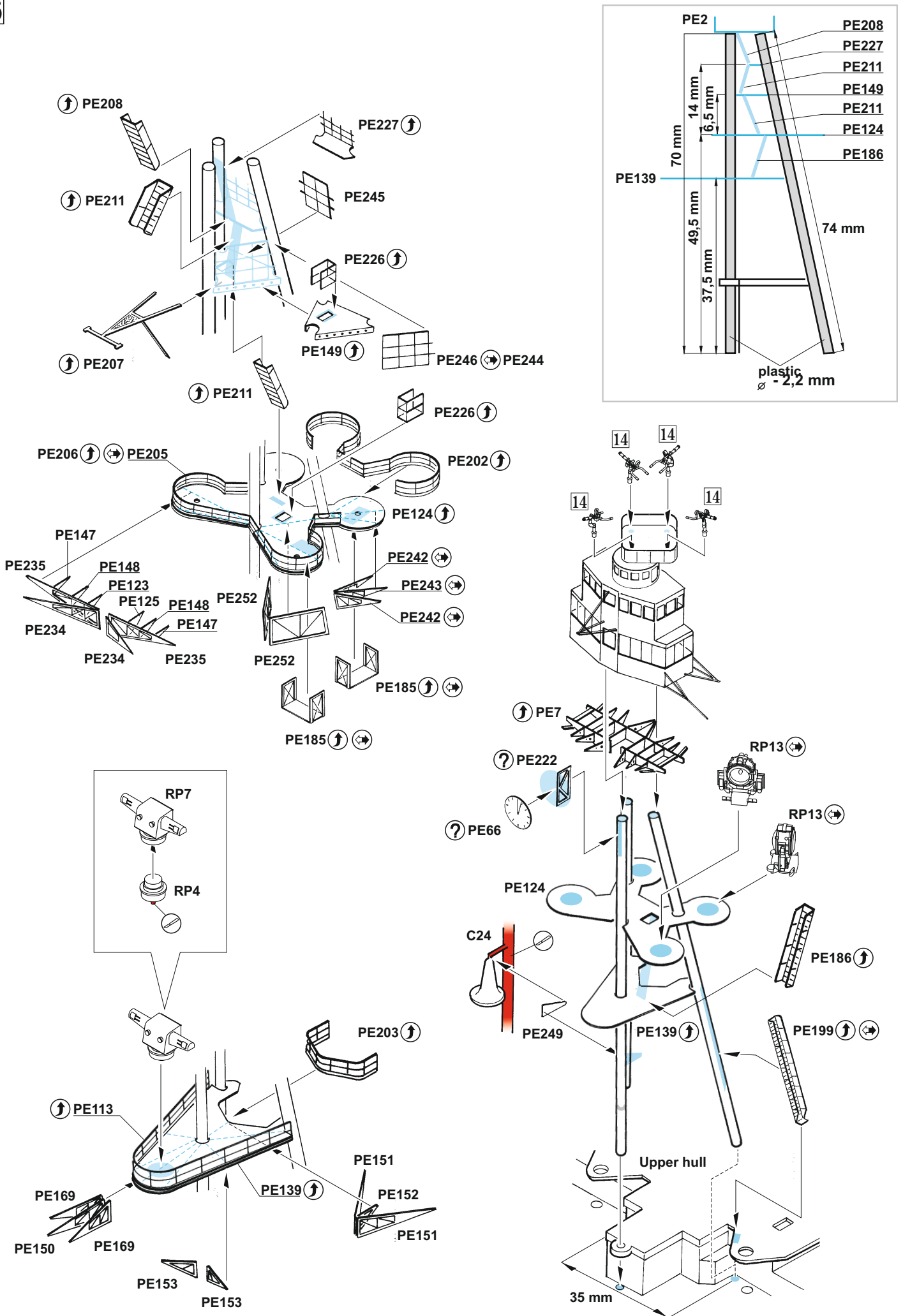

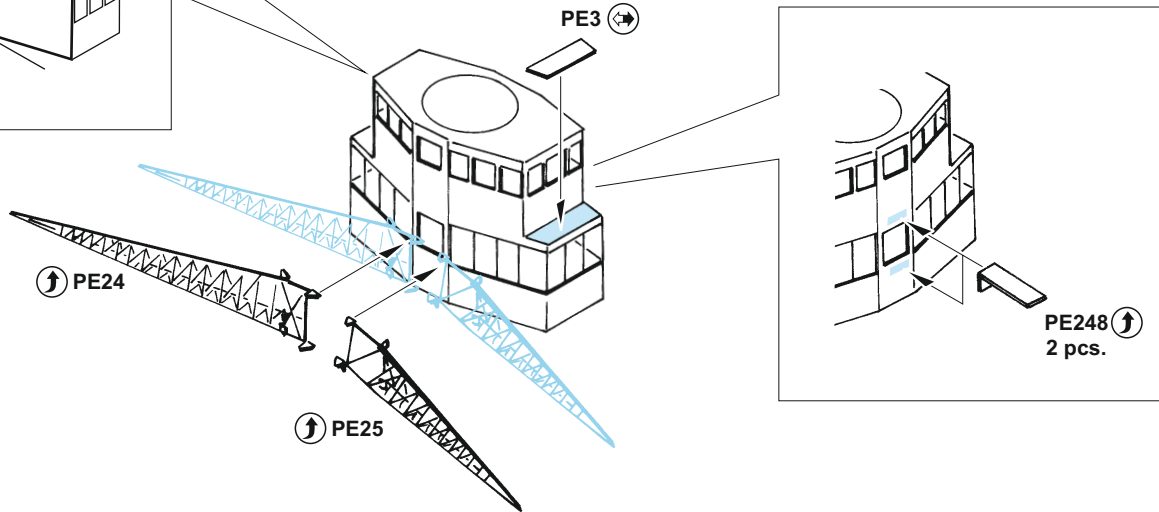
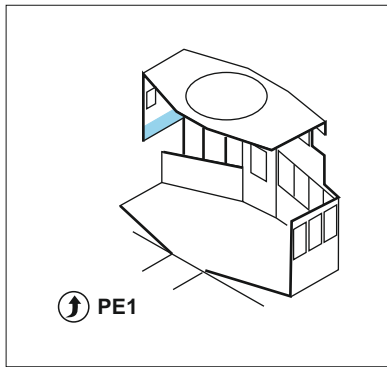
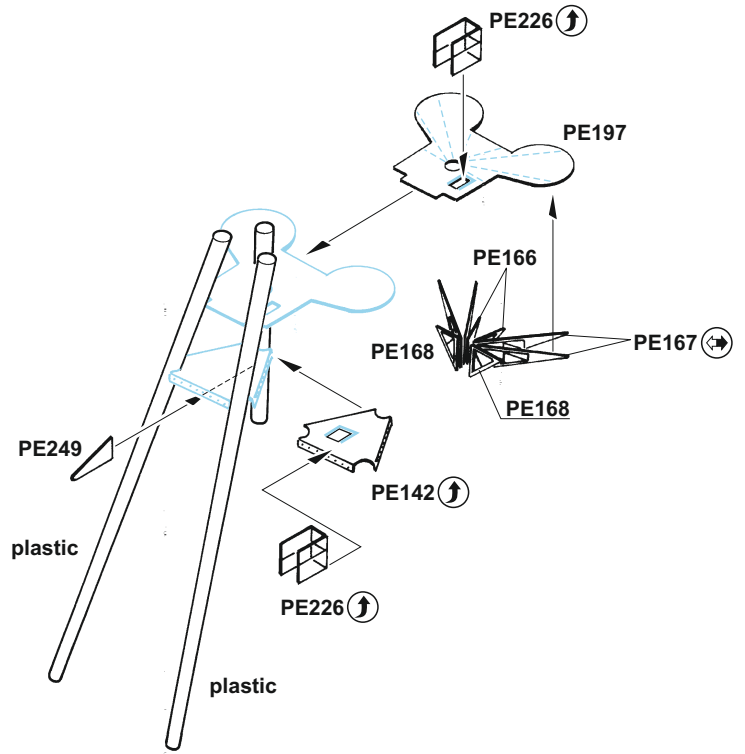
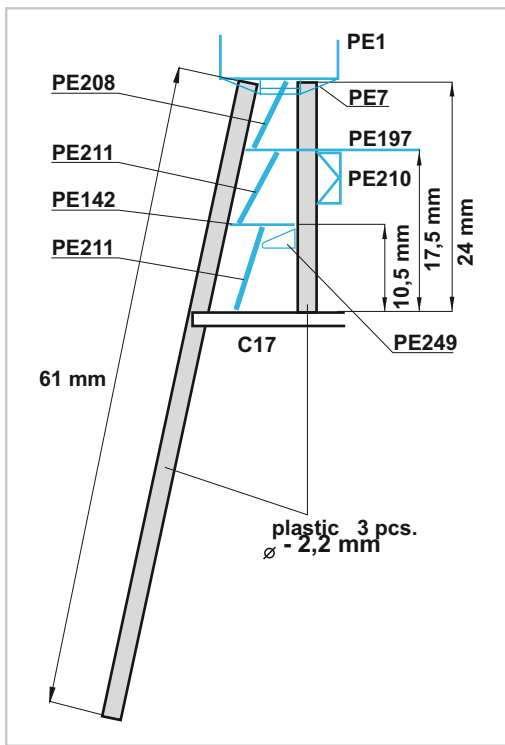

17

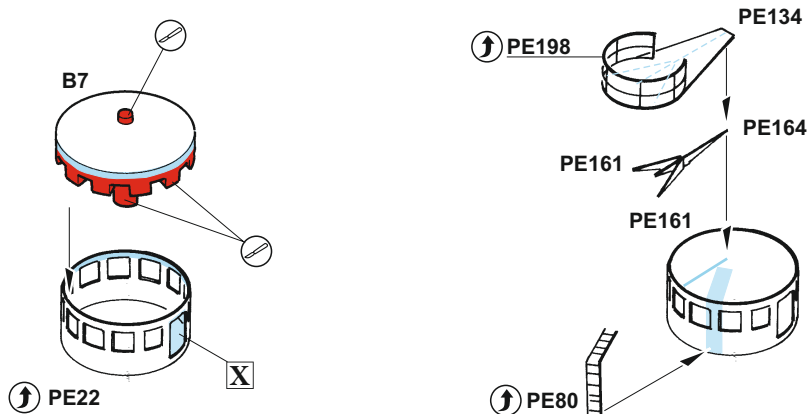

18

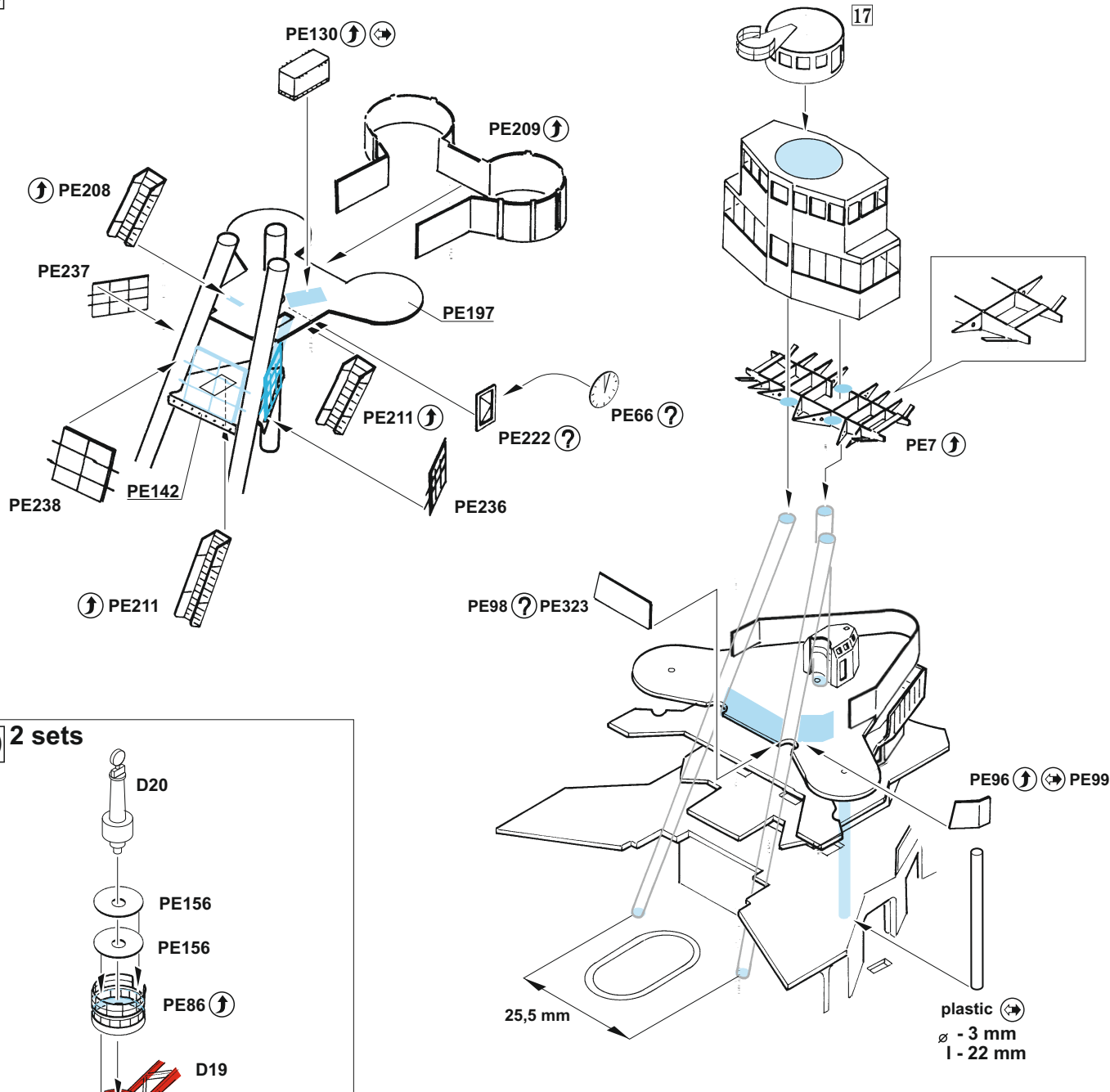

19 2 sets

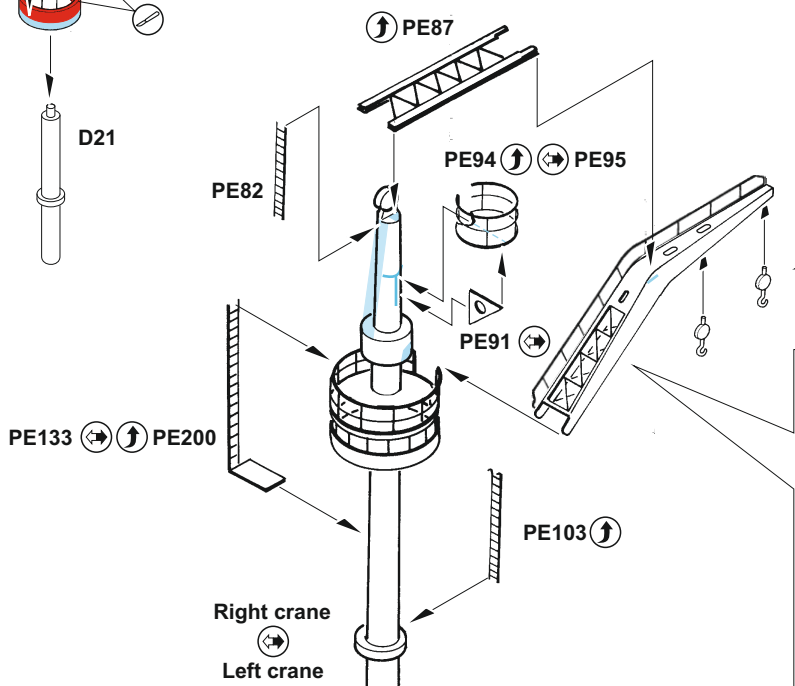
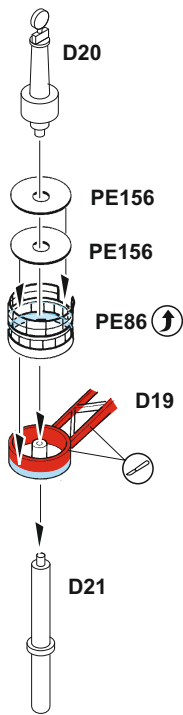

4 sets

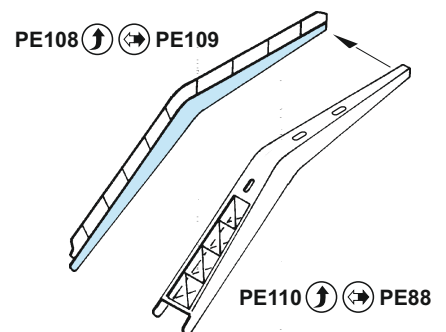
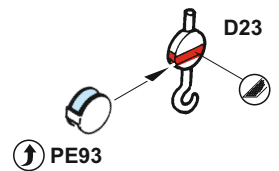

20 10 sets

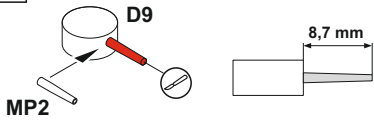

21 8 sets

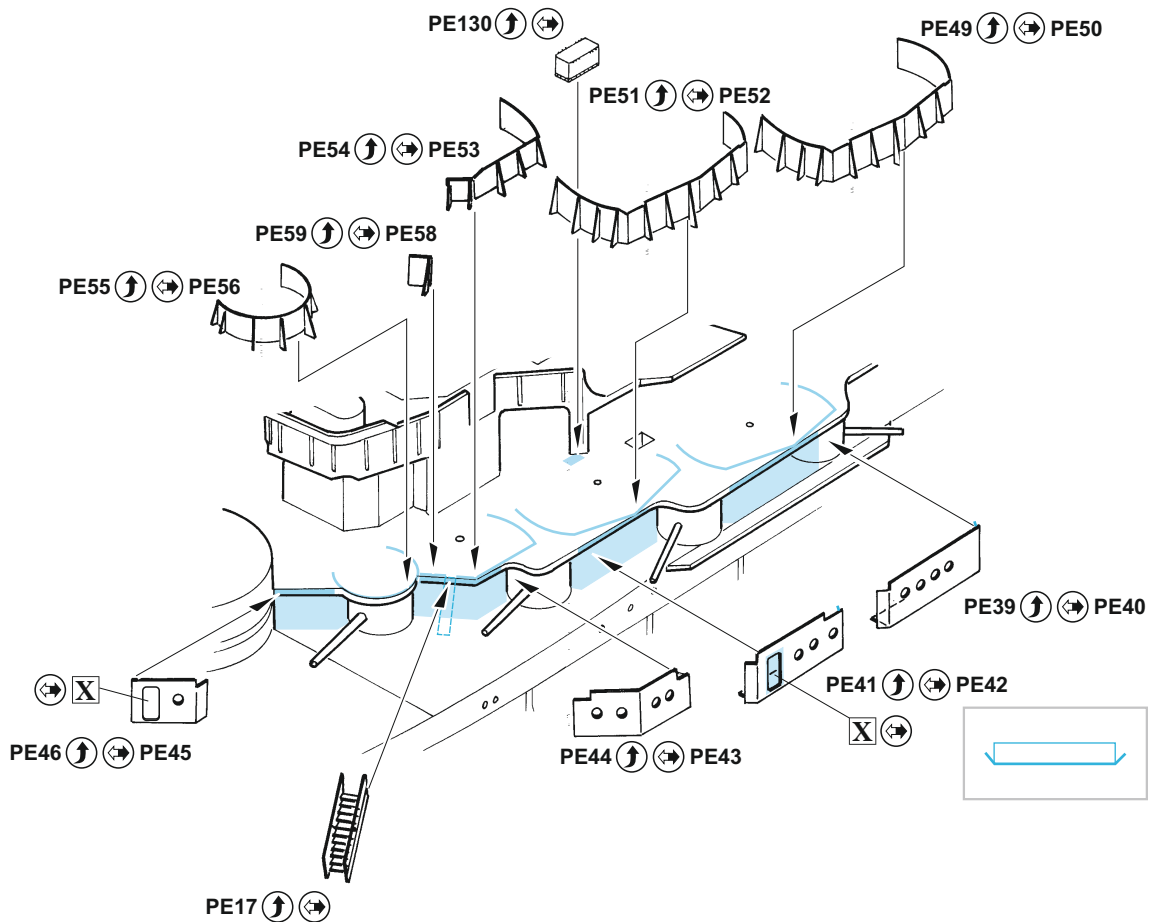
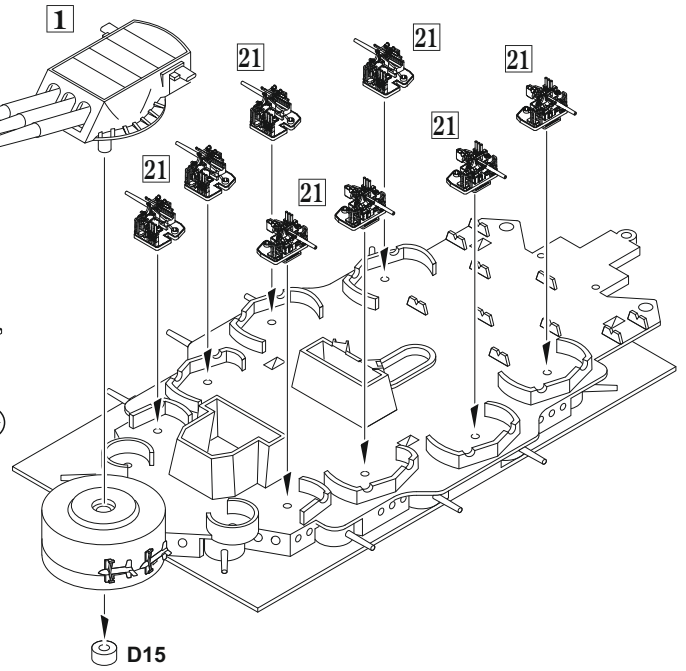
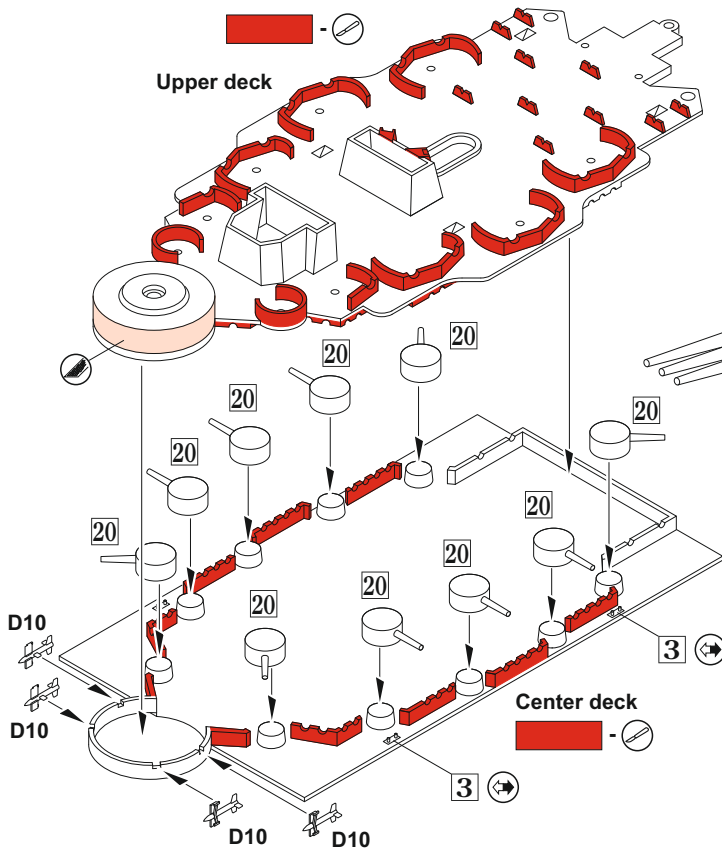
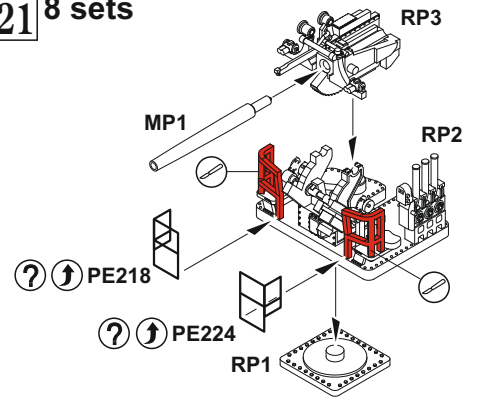

22 2 sets

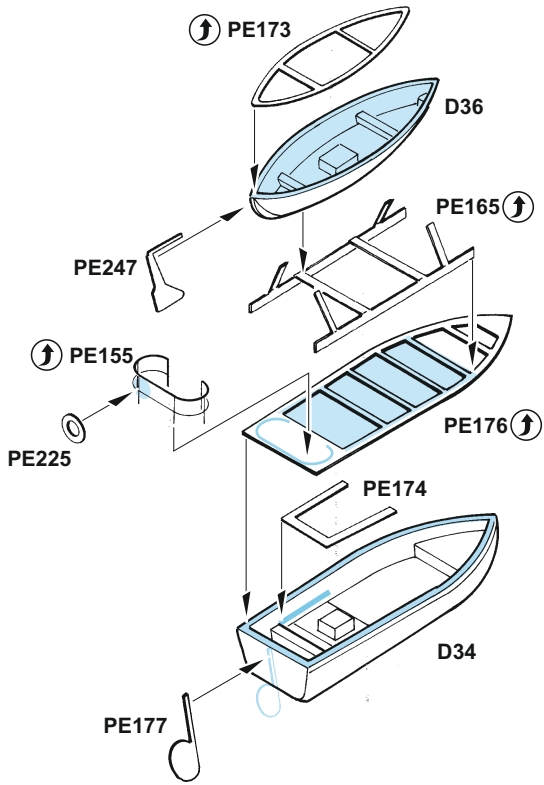

23 2 sets

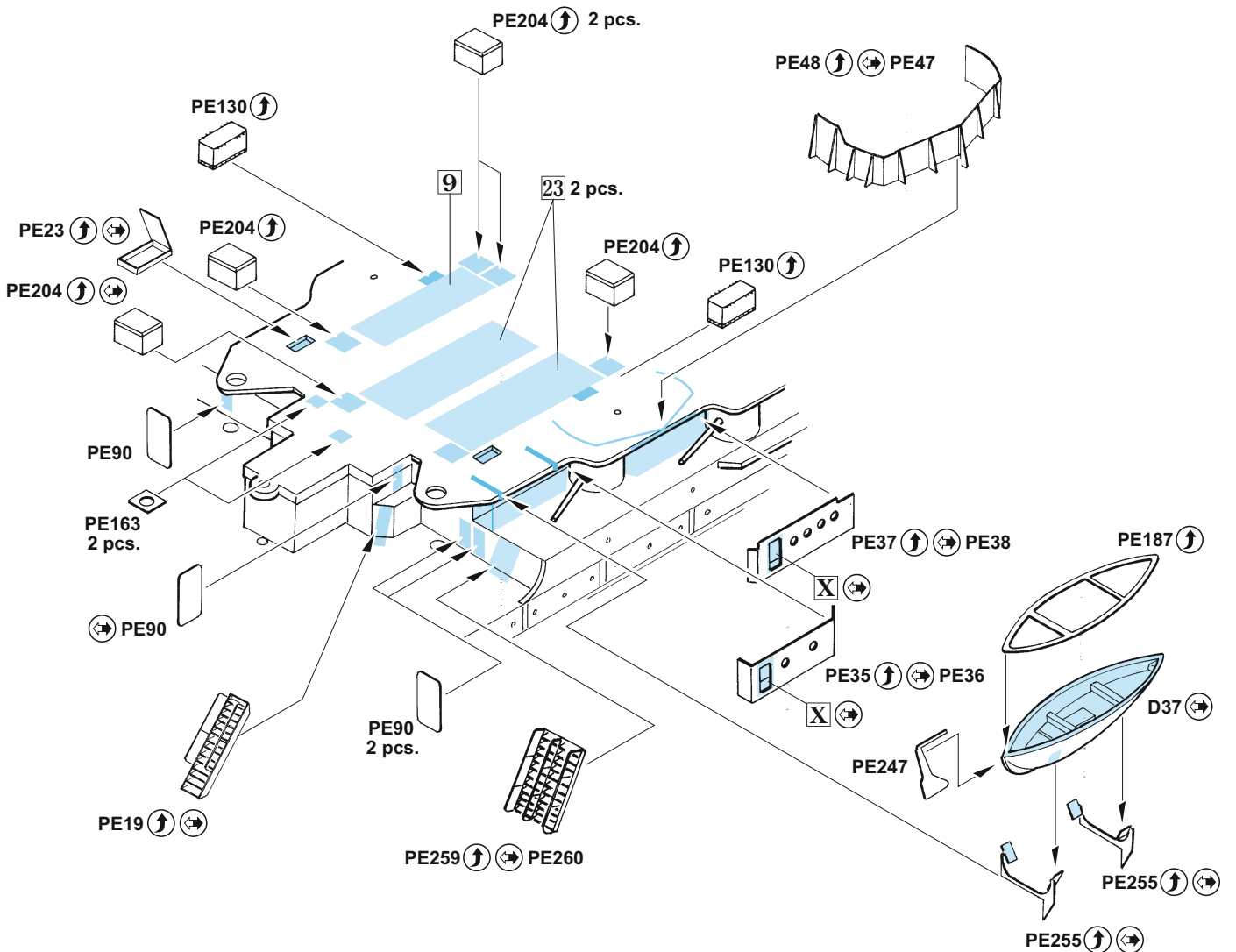
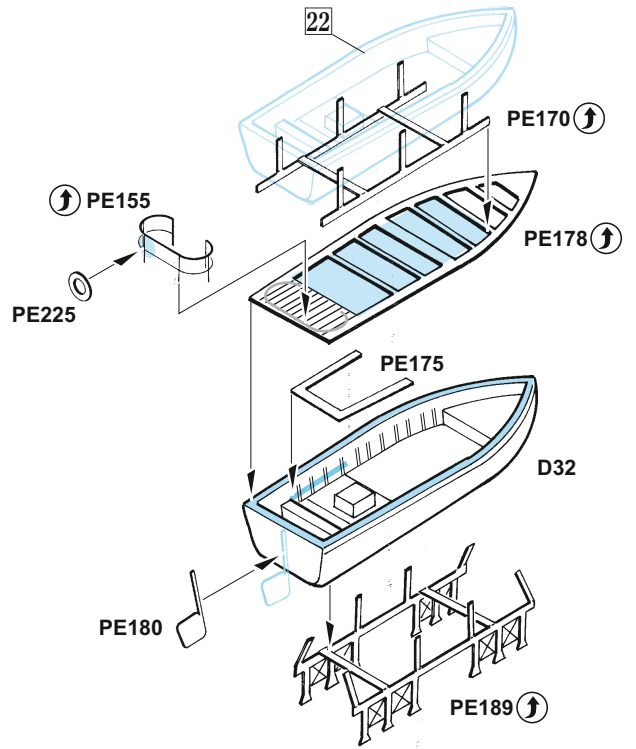

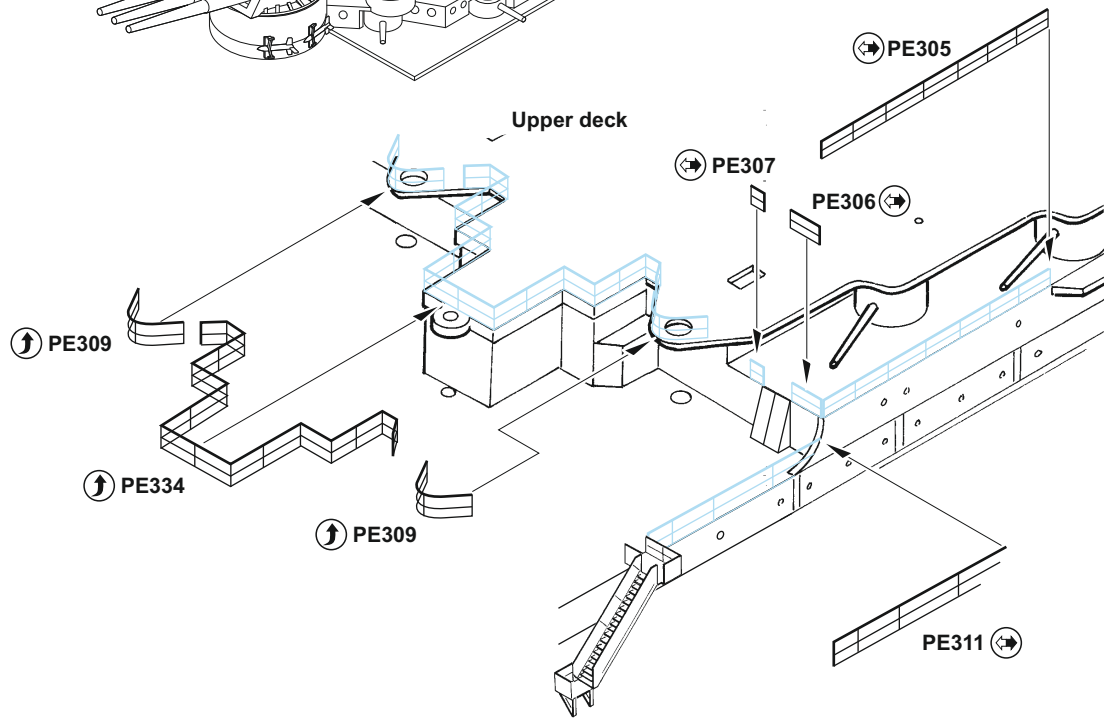
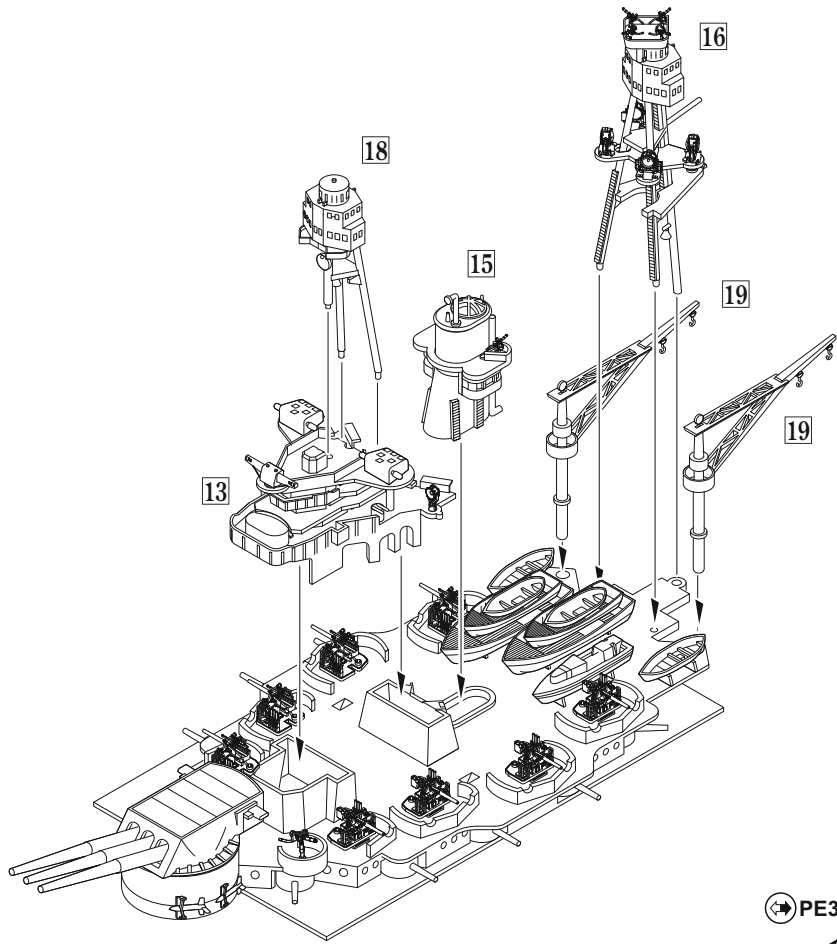

24 2 sets

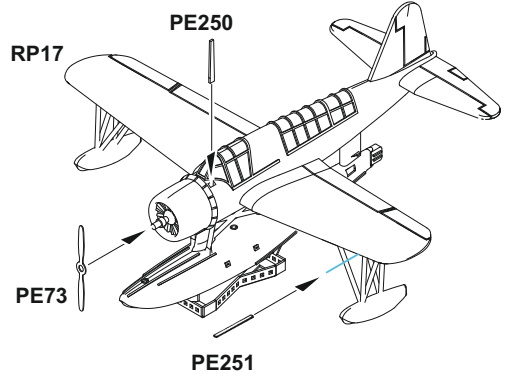
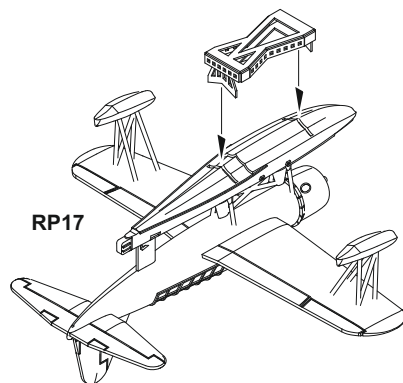
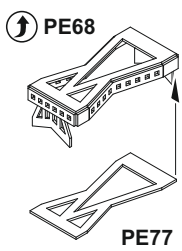

25

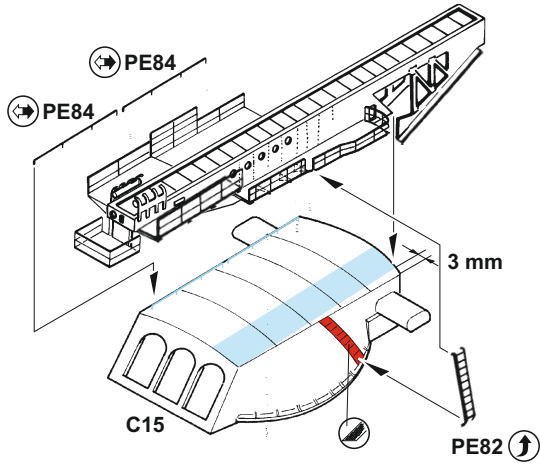
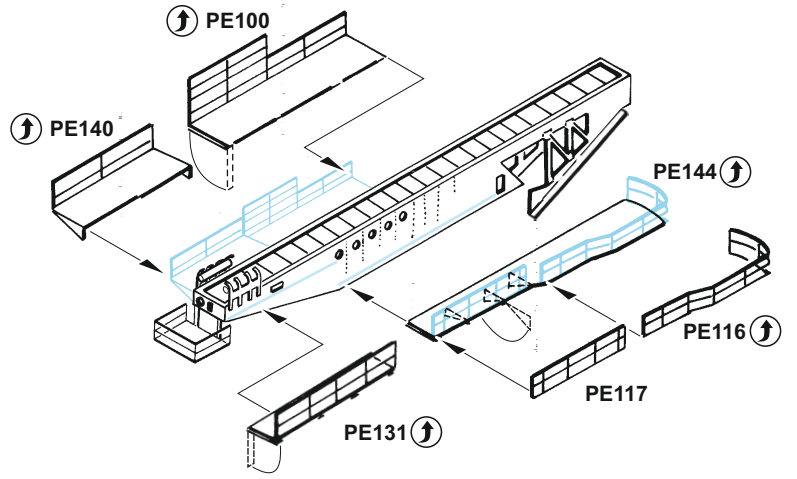
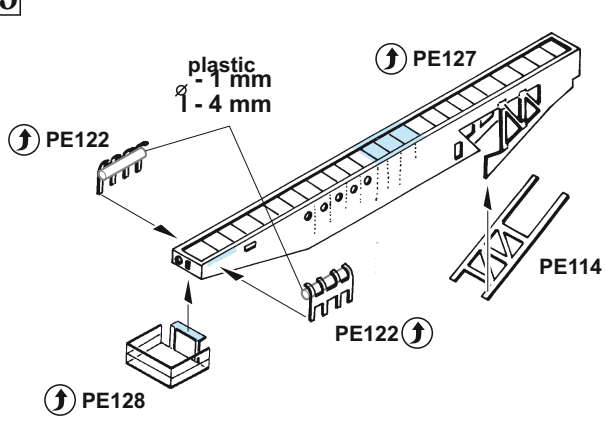

26

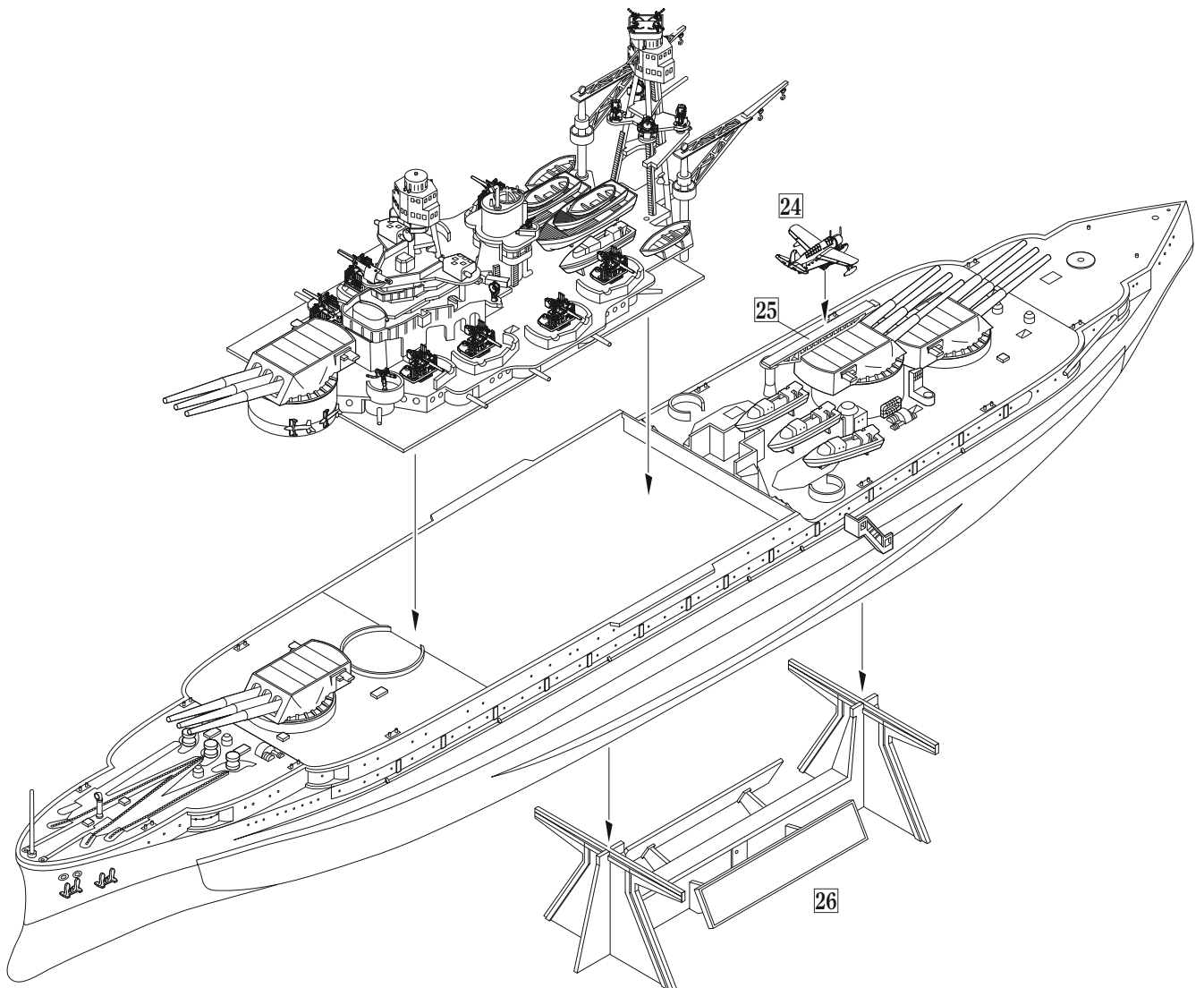
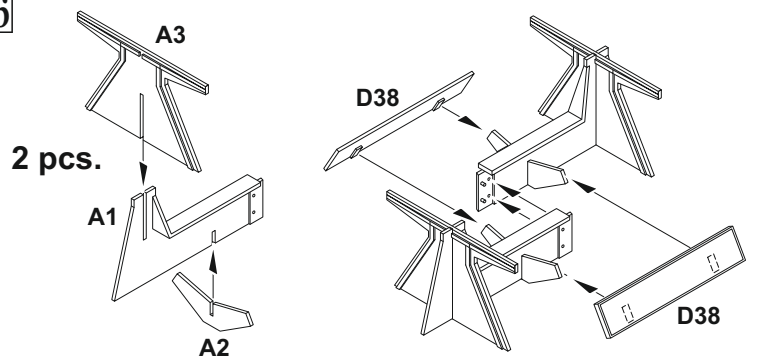

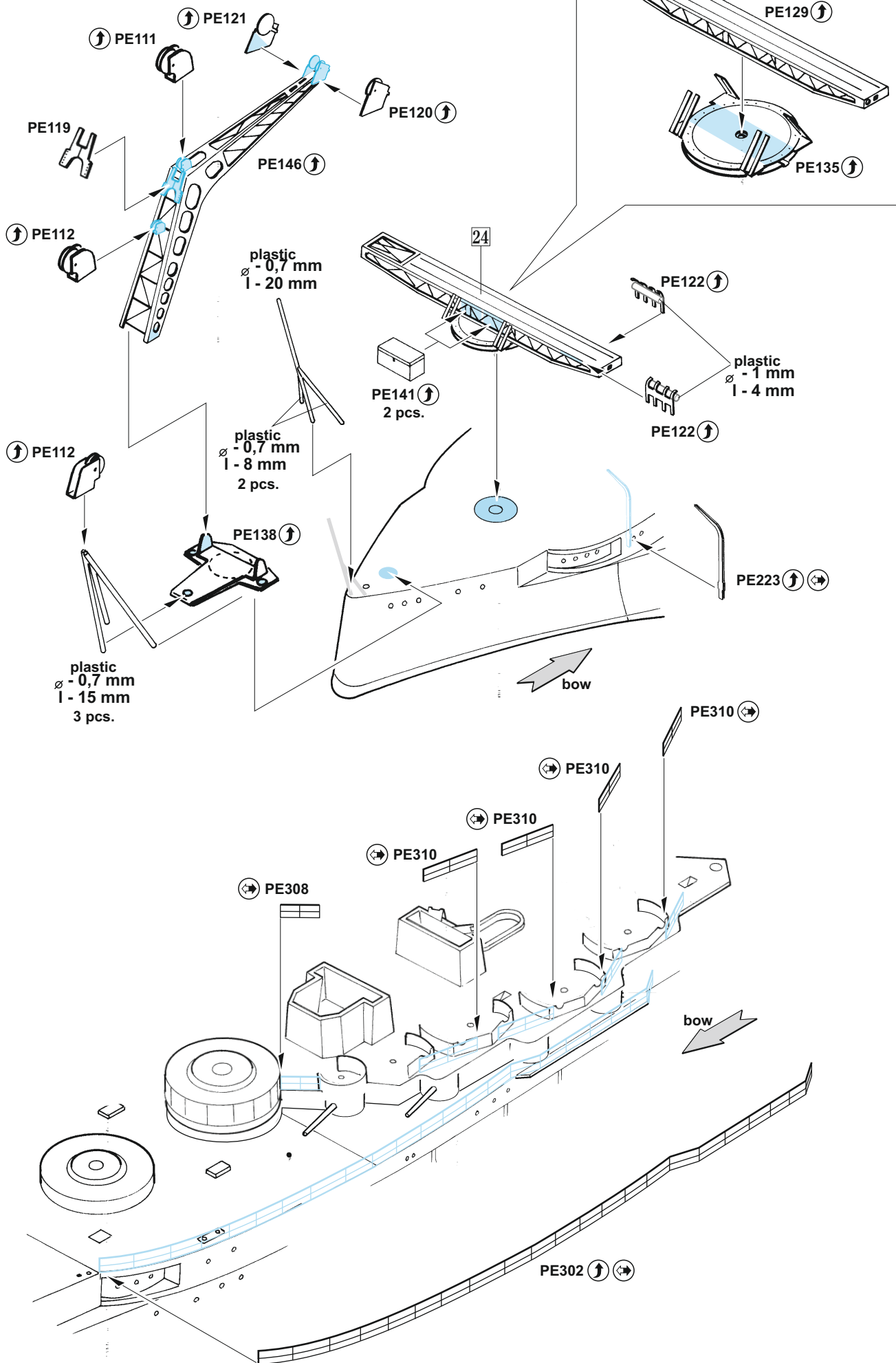

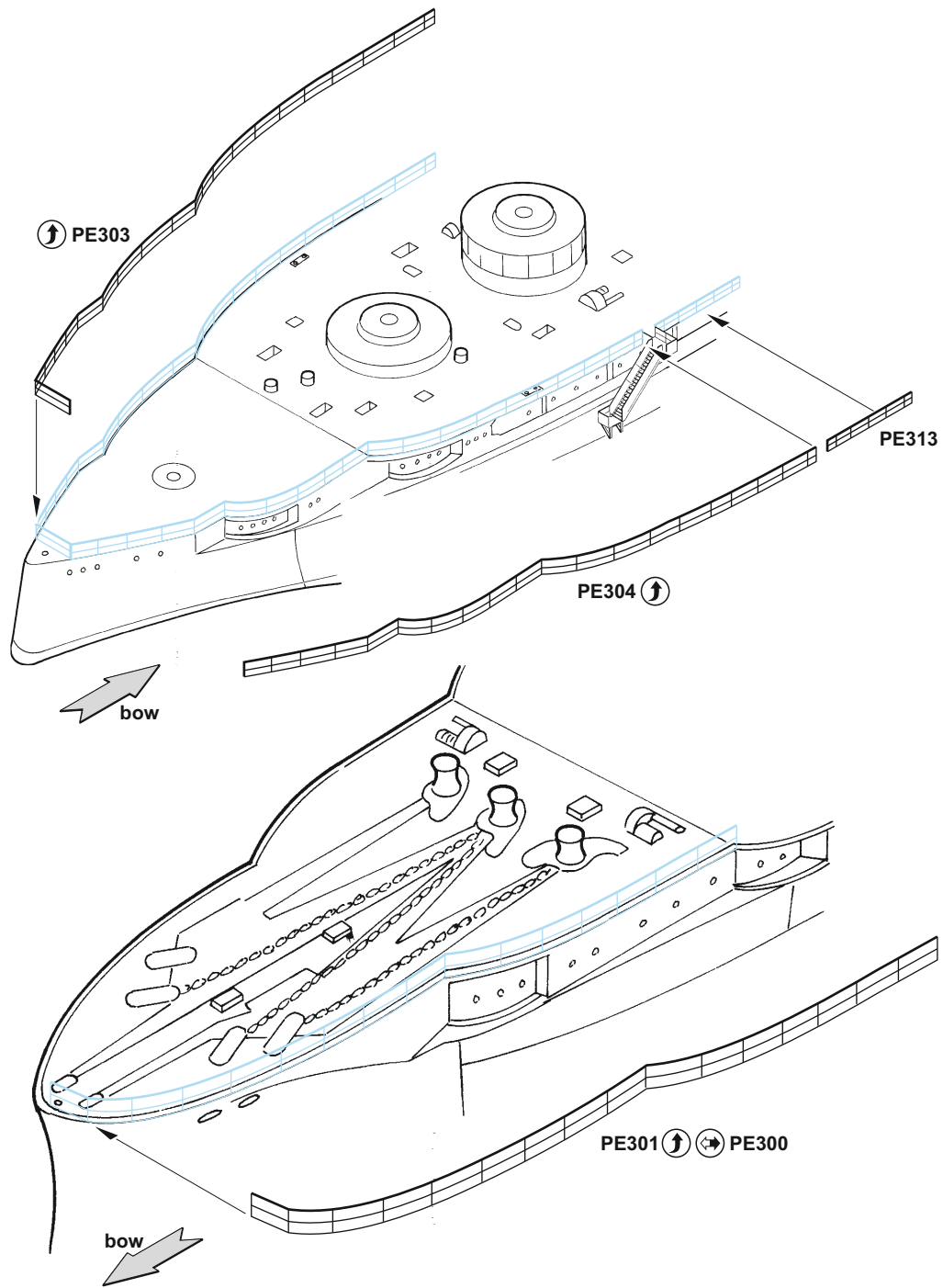

USS Arizona (BB-39), Pearl Harbor, Hawaii Islands, United States, December 1941

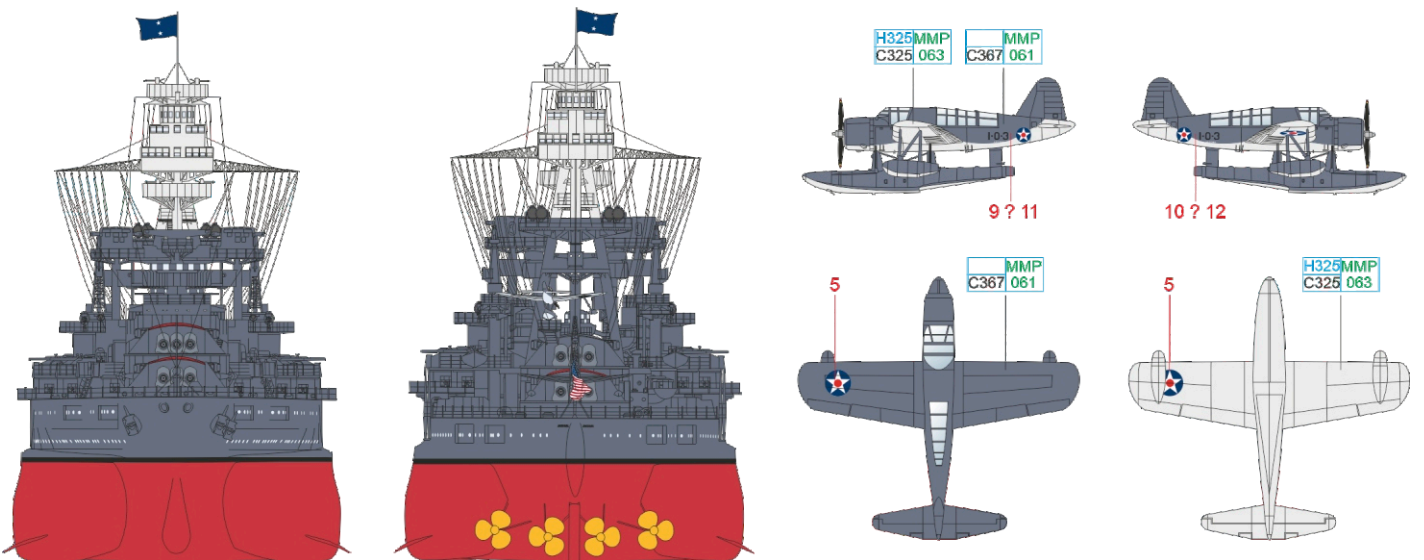

USS Arizona (BB-39), Pearl Harbor, Hawaii Islands, United States, December 1941

